

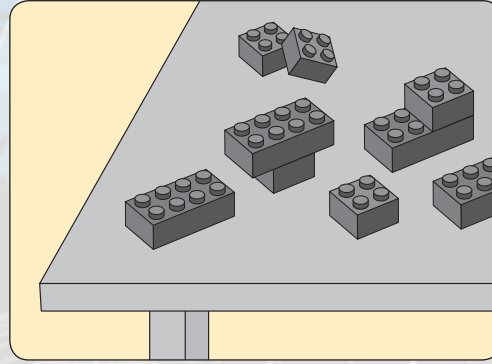

9483

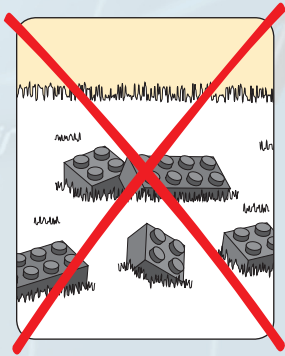

1



2



2

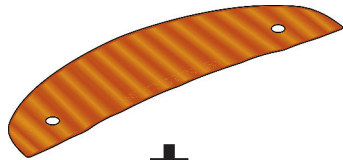

+

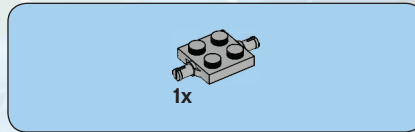
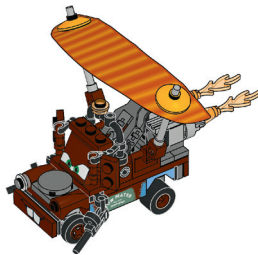

1

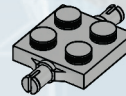

3

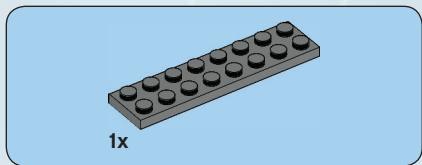

2

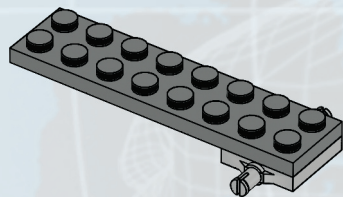

4

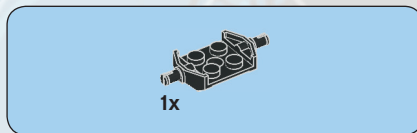

3

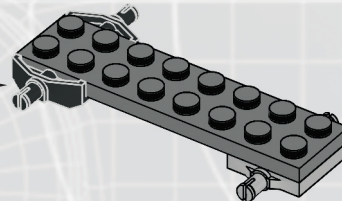
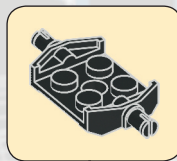

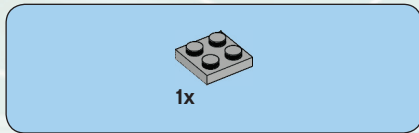

4

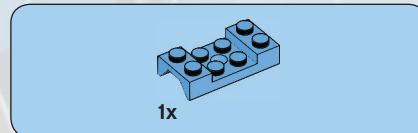
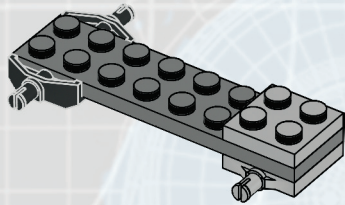

5

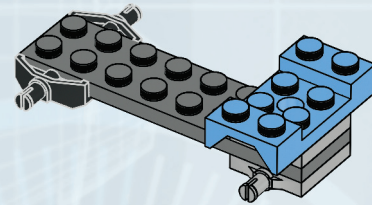

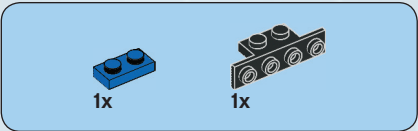

6

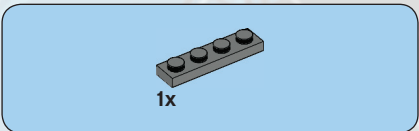
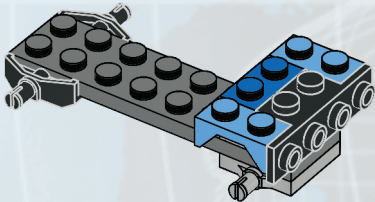

7

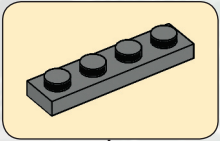
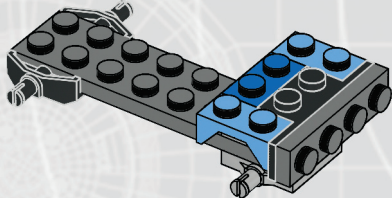



8

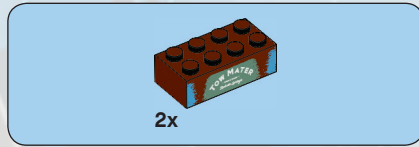
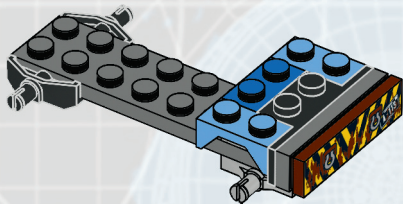

9

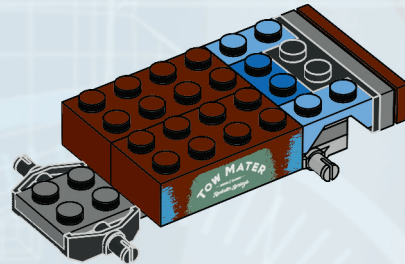



1x

10

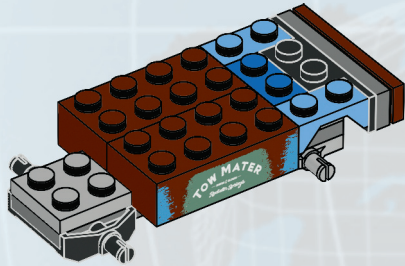

8



1x

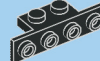

1x

11

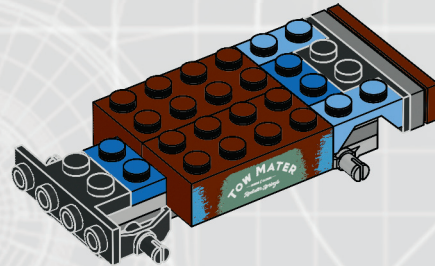



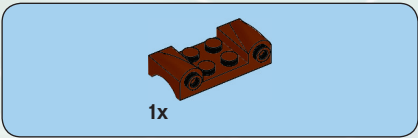

12

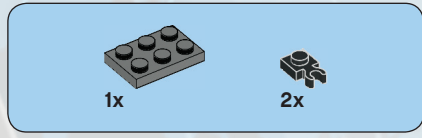
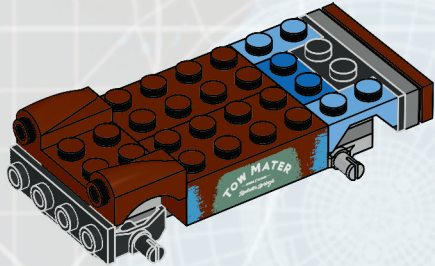

13

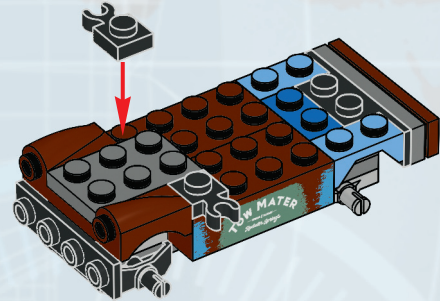

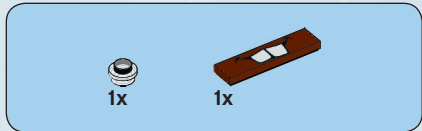

14

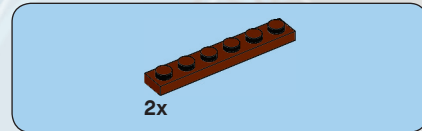
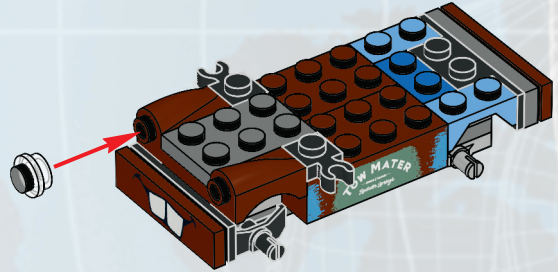

15

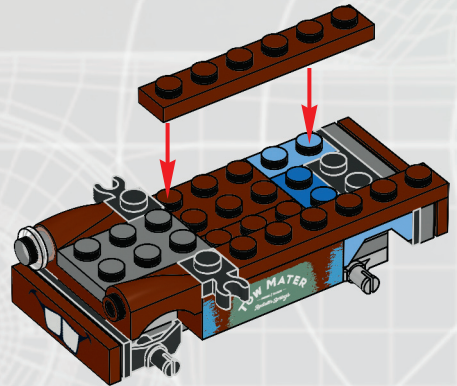

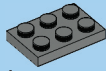

1x

16

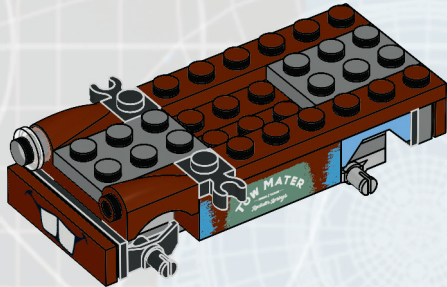

4x

17

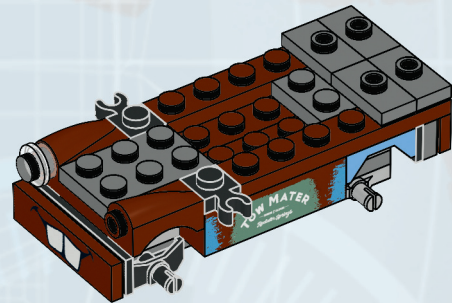

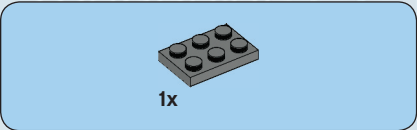
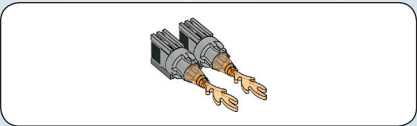

**1**

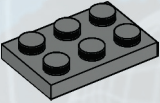

**2**

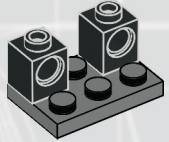

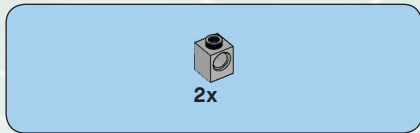

3

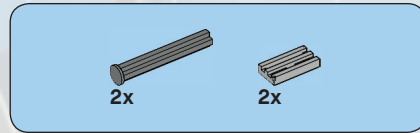
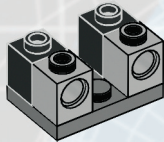

4

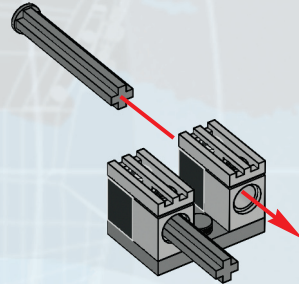

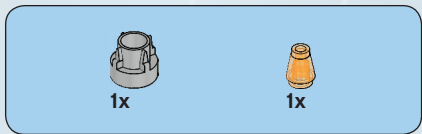

# 5 *waypoint*

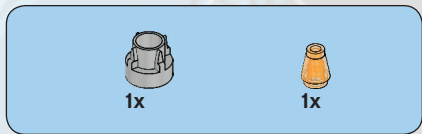
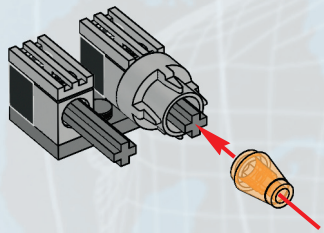

# 6

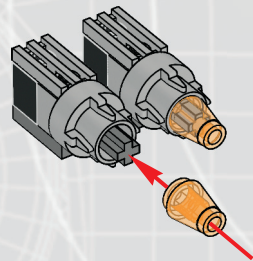

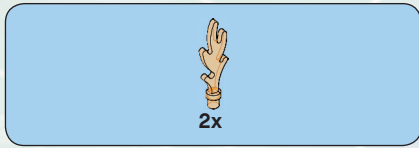

7

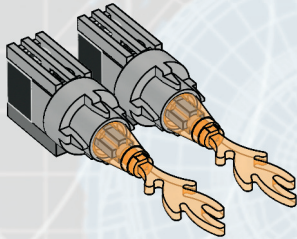

target  
acquired

18

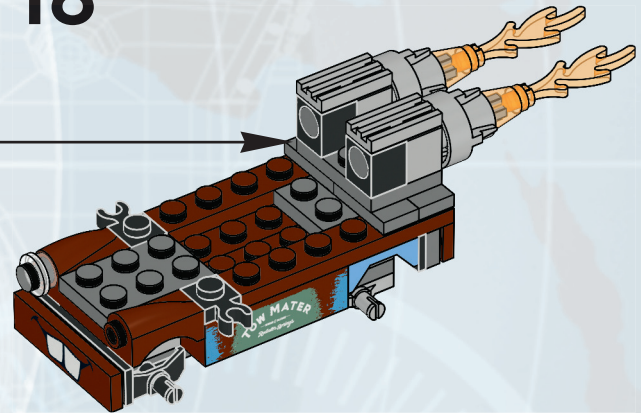



19

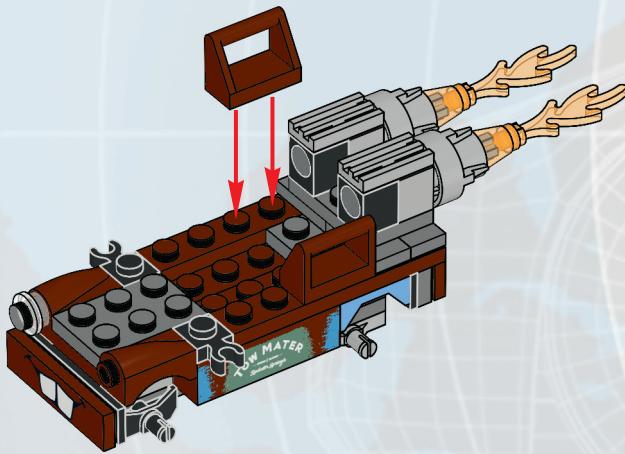

16

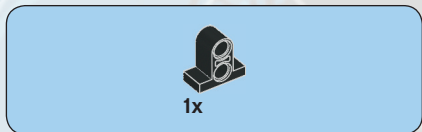

20

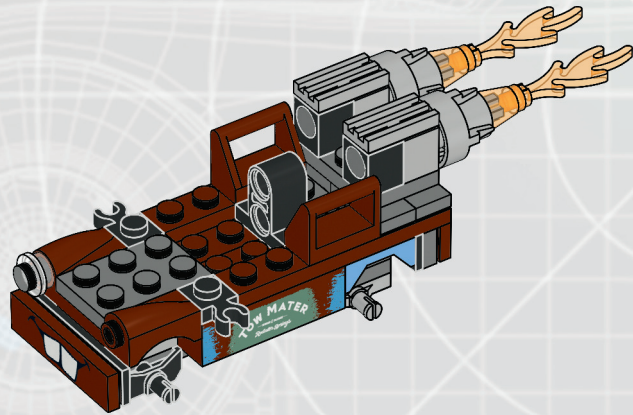



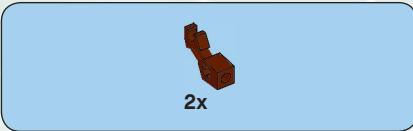

21

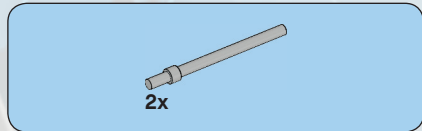
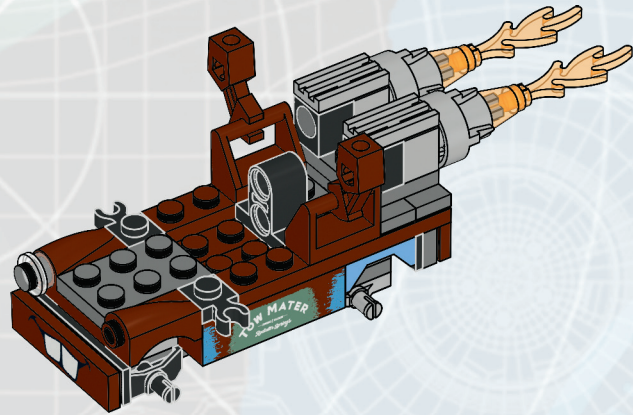

22

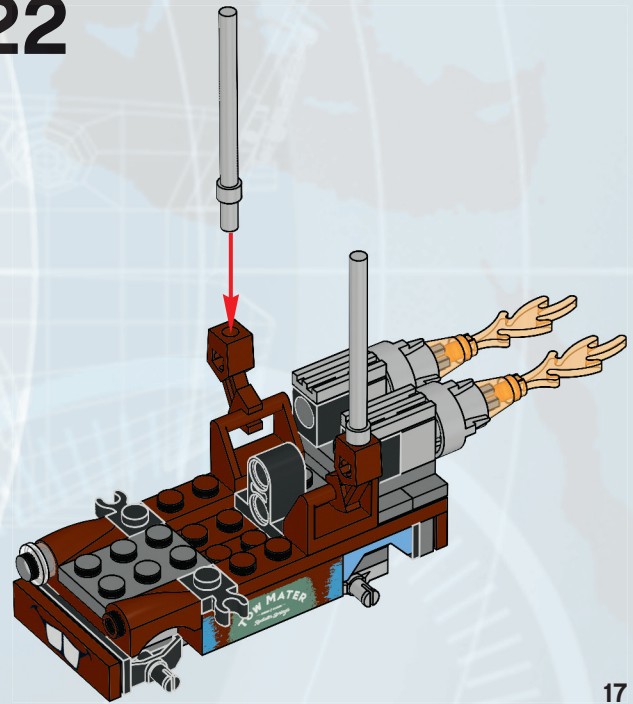

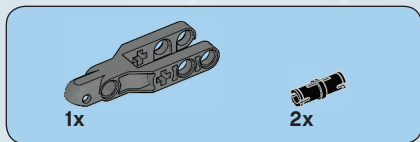

1

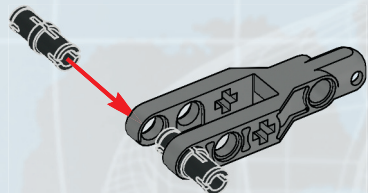

2

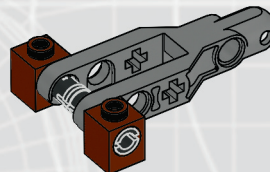

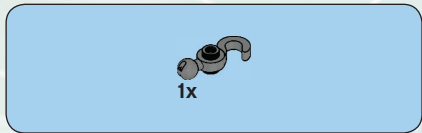

3

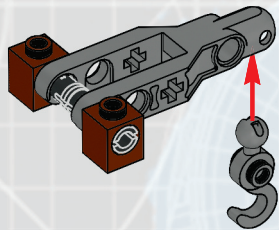

23

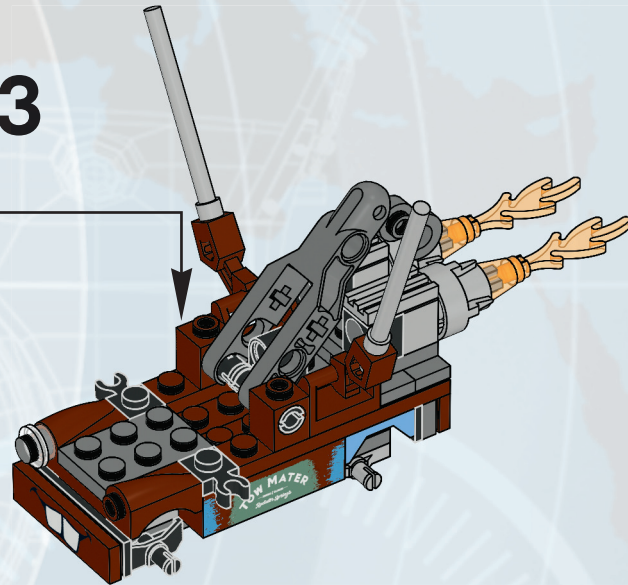

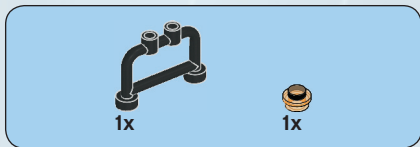

24

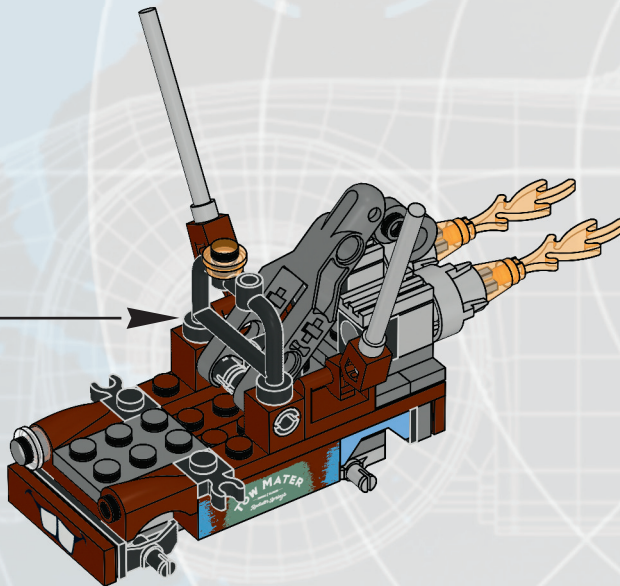
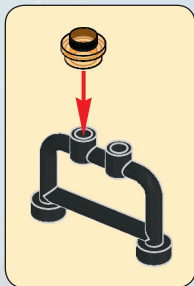

20



25

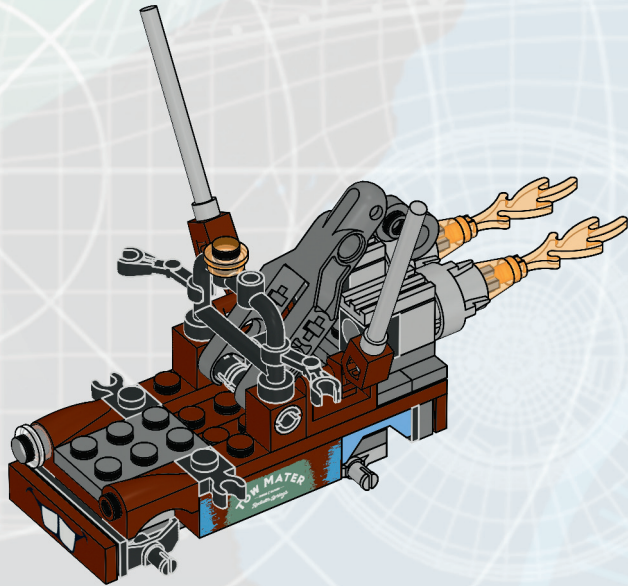

26

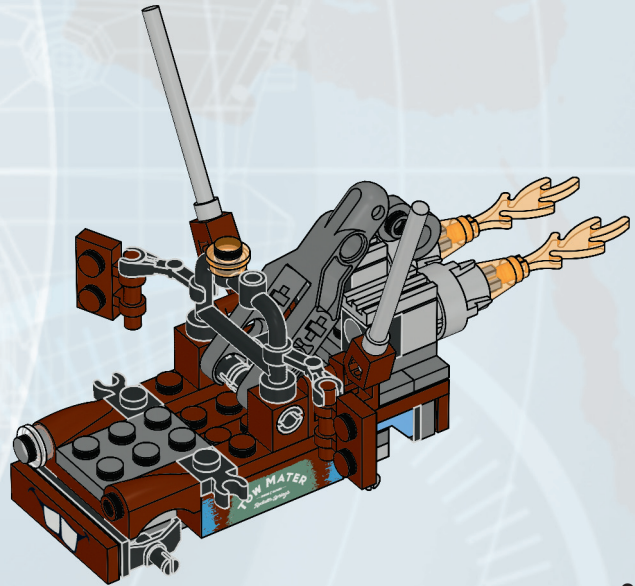

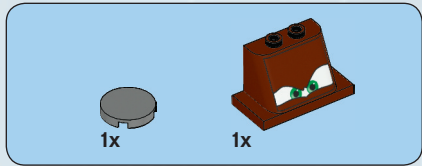

27

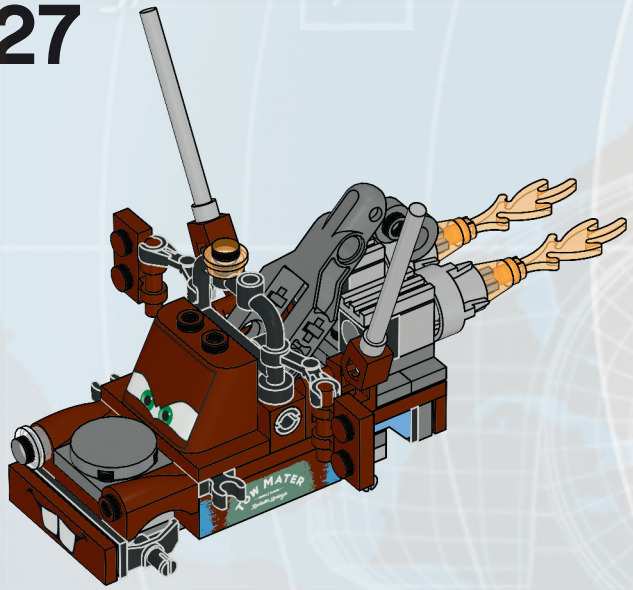

28

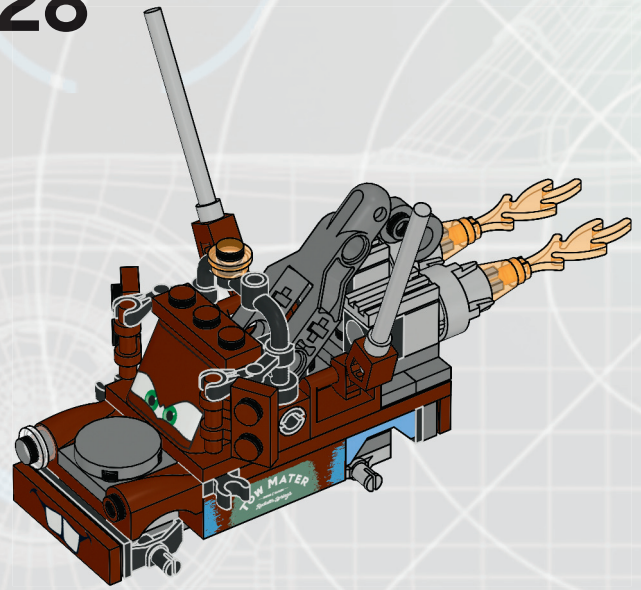

22

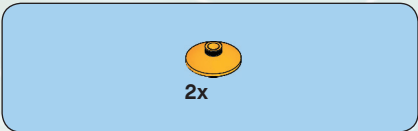

29

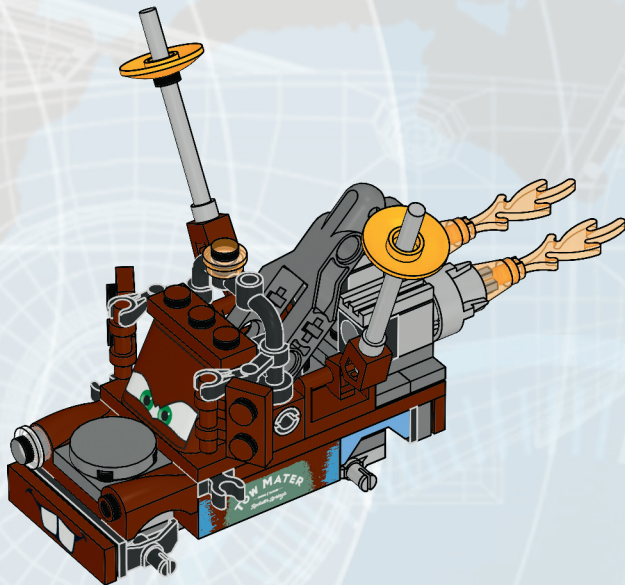

point 2  
target acquired

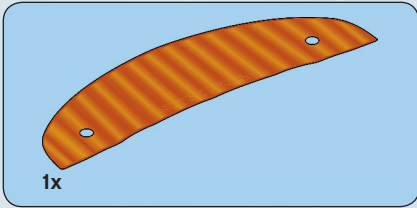

30

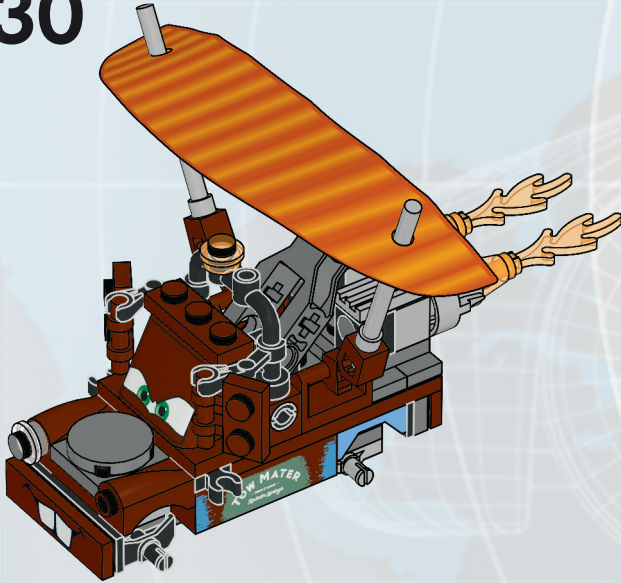

24

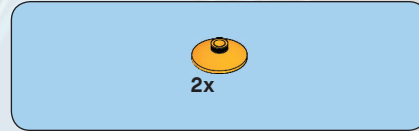

31

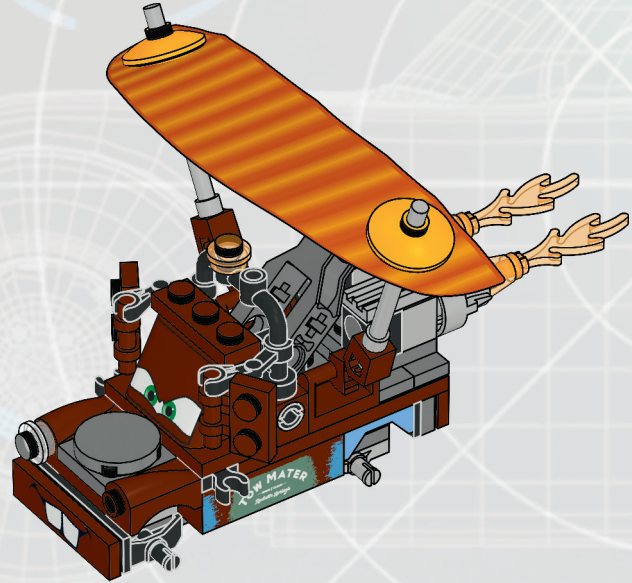





2x



2x

# 32



2x

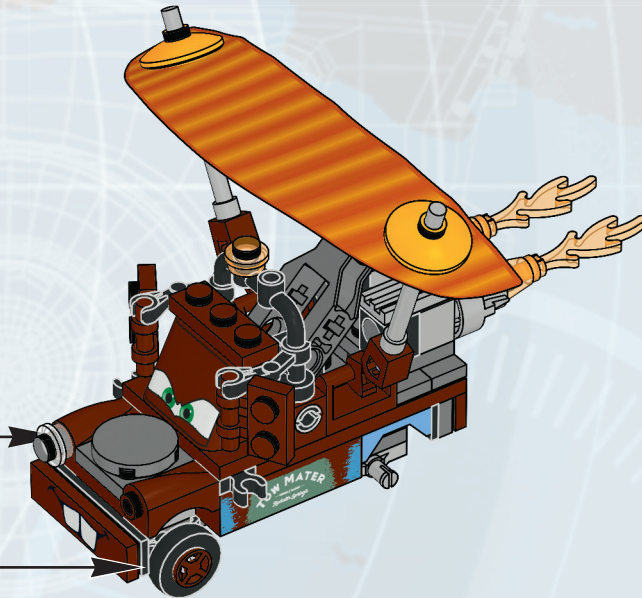



33

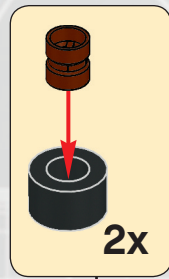
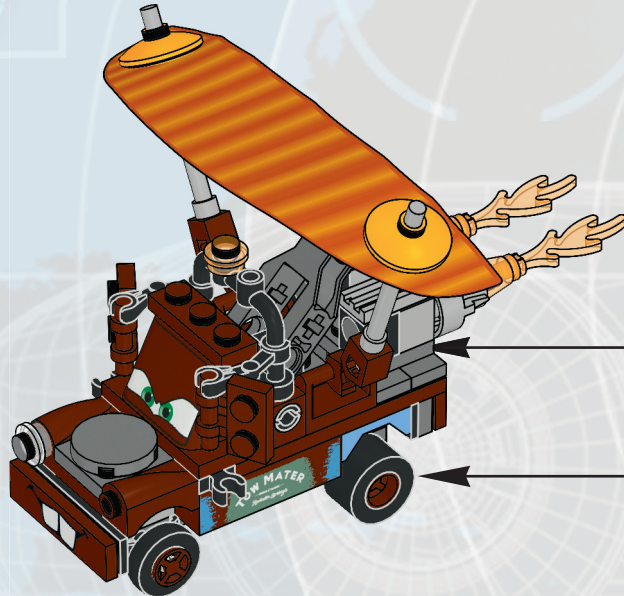



34

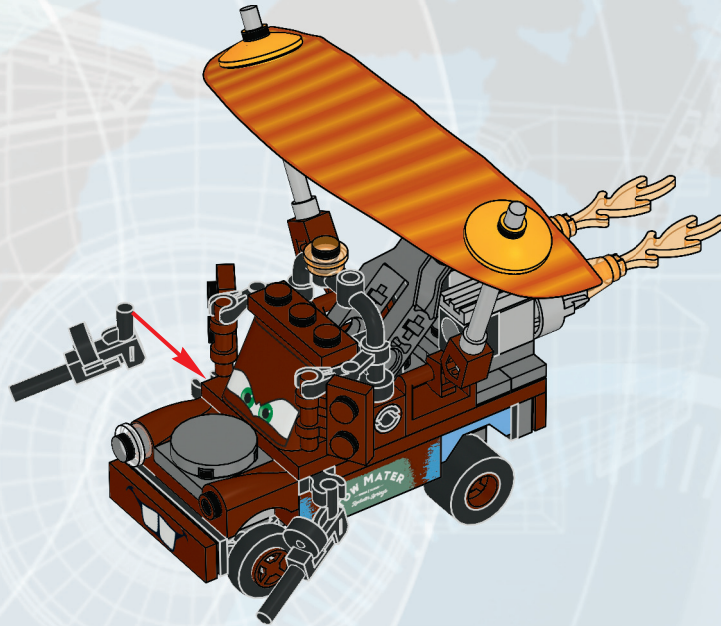

point 2  
target acquired

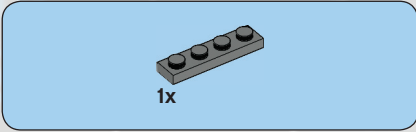
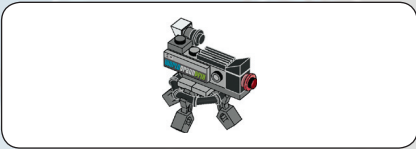
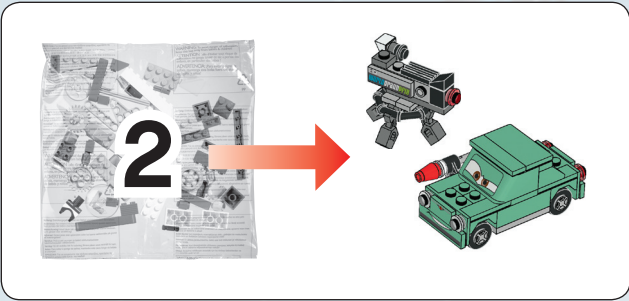

1

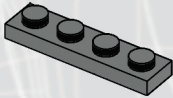



**2**

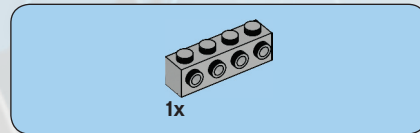
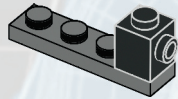

**3**

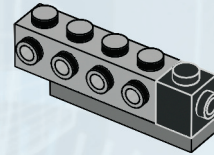

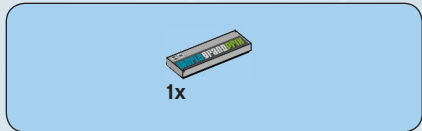

4

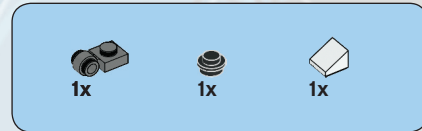
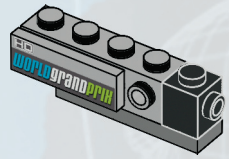

5

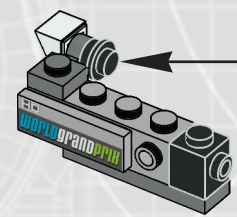
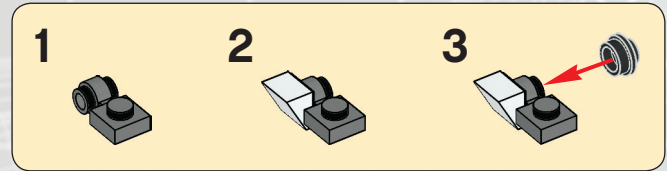



1x



1x

6

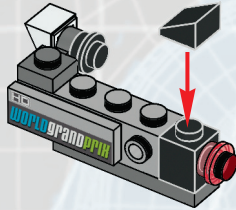

1x

7

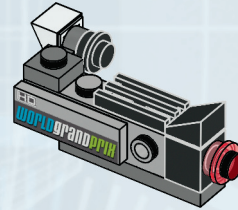



# 8

1



2



3

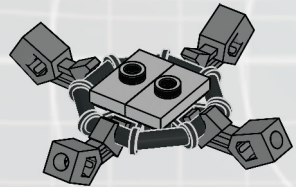



waypoint 2

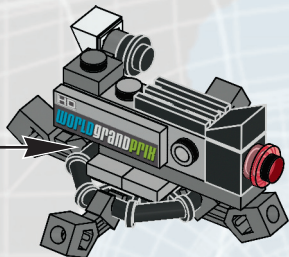

target acquired

9

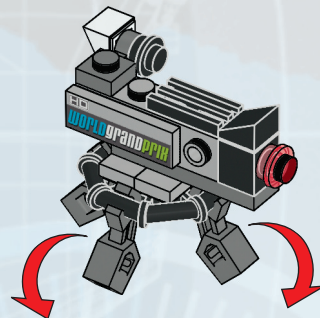

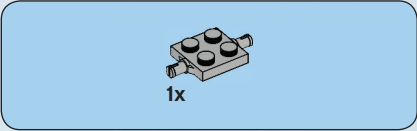
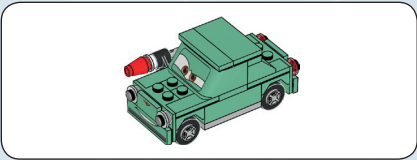

1

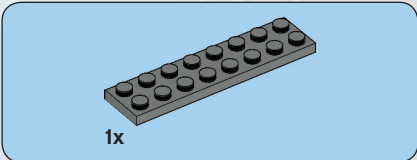
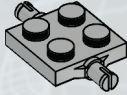

2

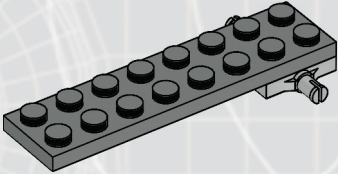

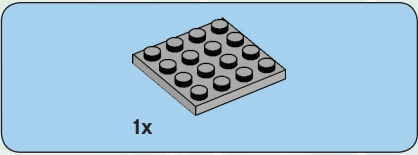

**3**

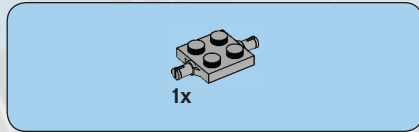
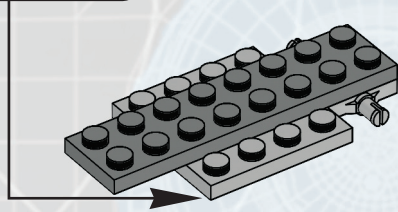
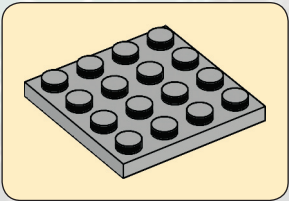

**4**

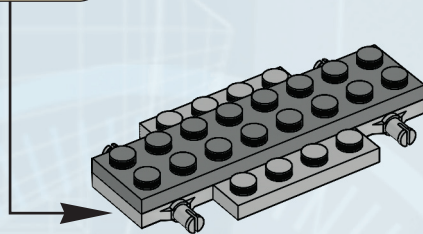
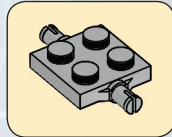

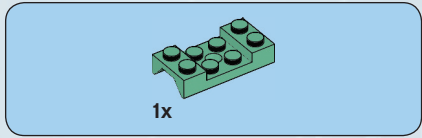

5

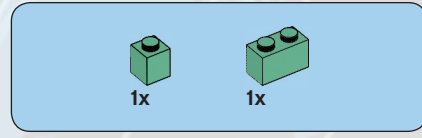
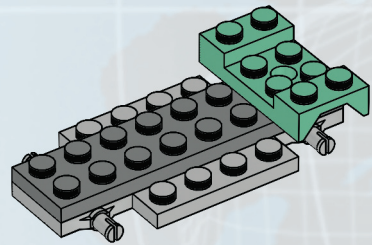

6

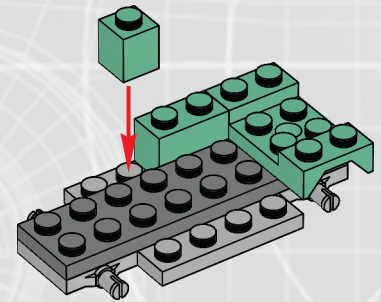

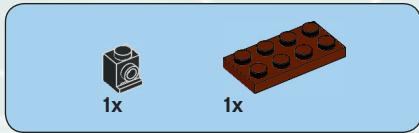

7

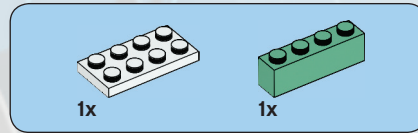
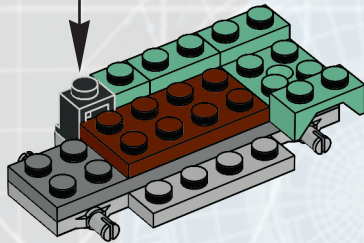

8

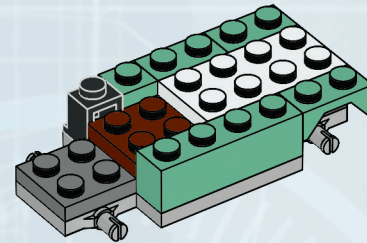

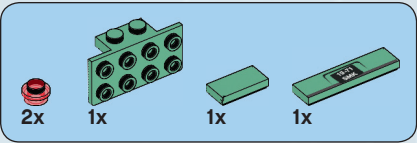

9

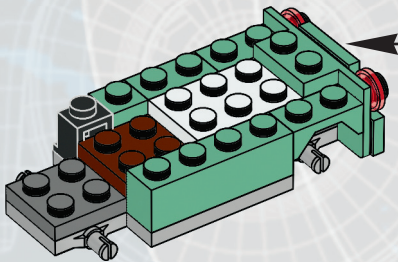
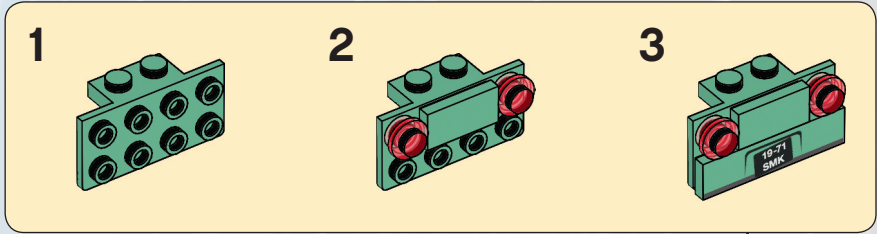

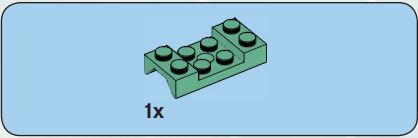

10

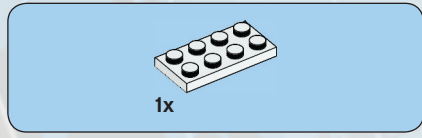
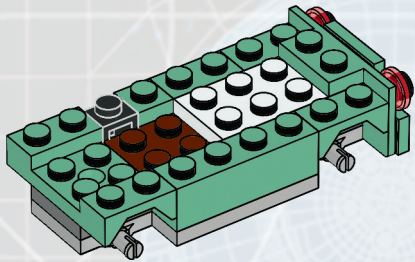

11

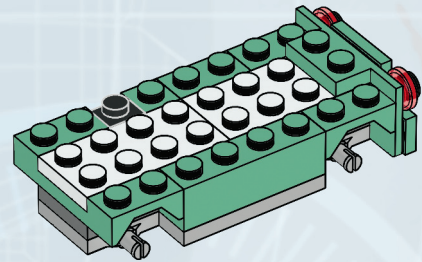

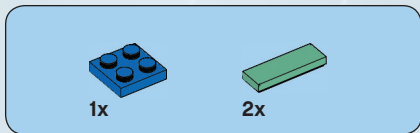

12

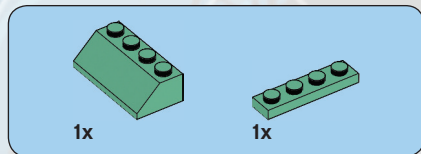
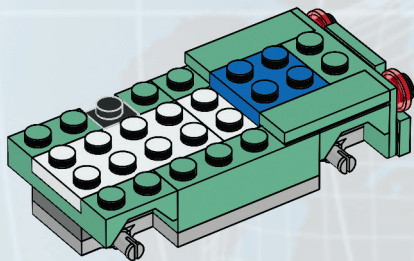

13

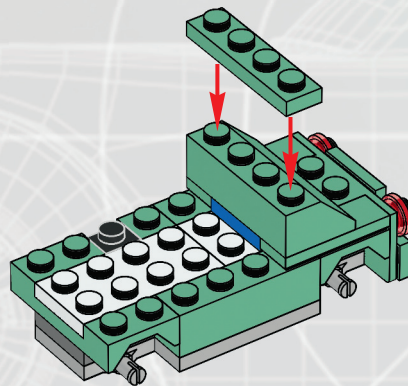



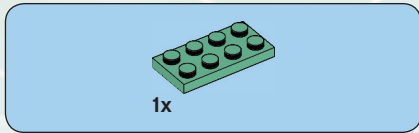

14

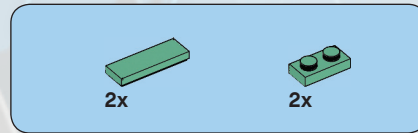
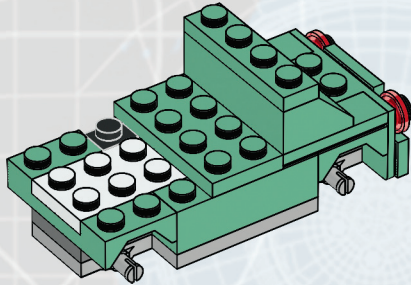

15

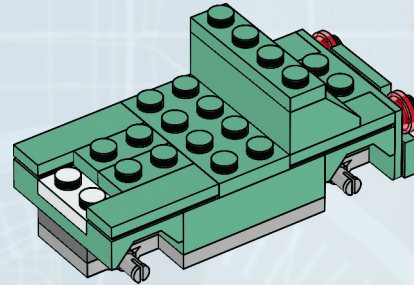

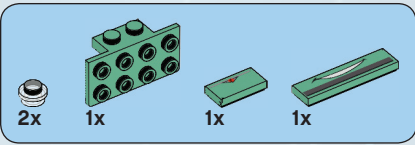

16

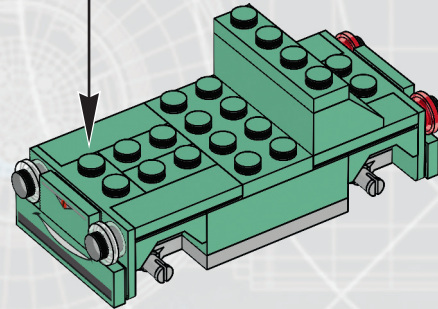
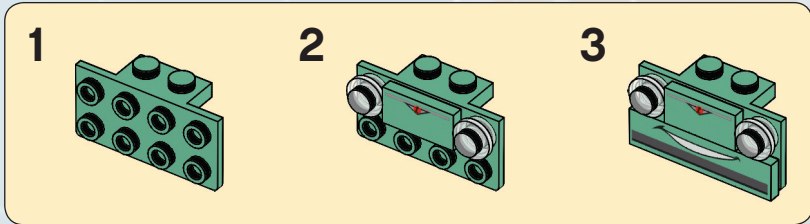

42

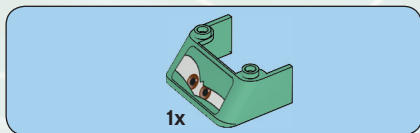

17

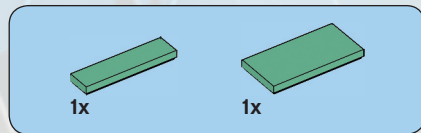
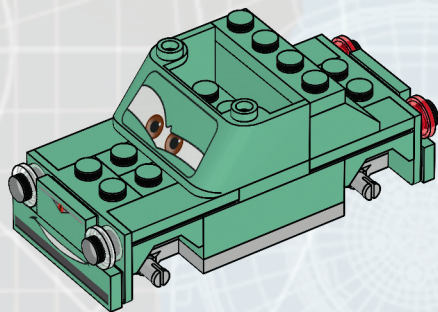

18

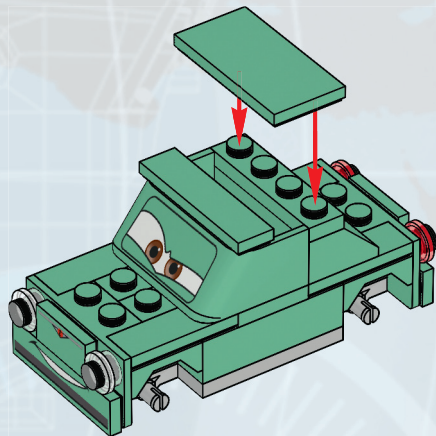



19

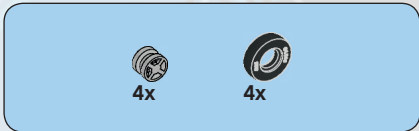
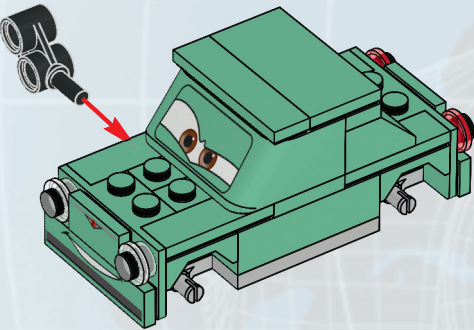

20

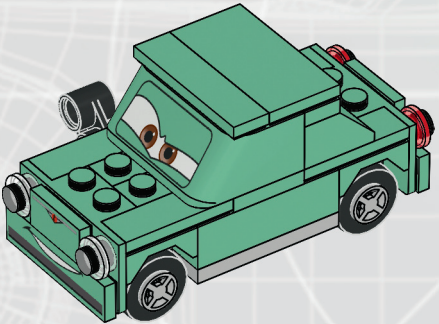

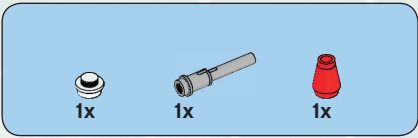

21

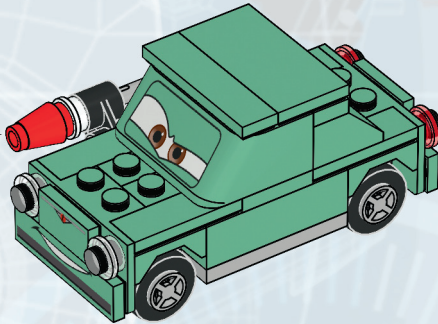
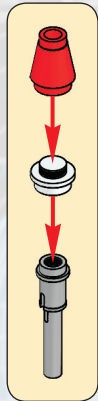

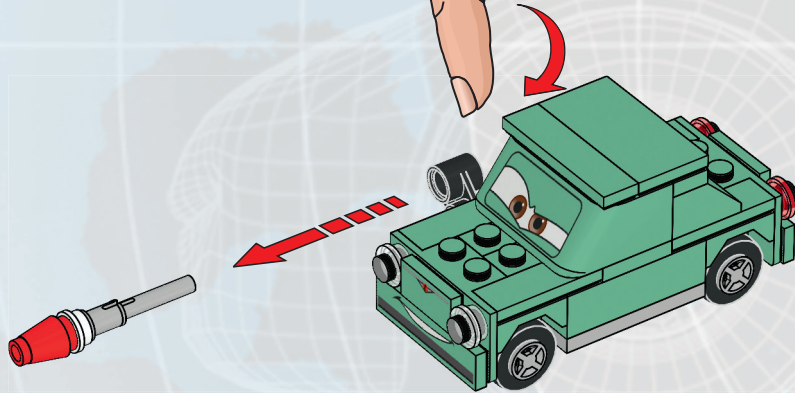

1x  
4504369

2x  
654126

2x  
4223247

1x  
4654964

1x  
4633698

1x  
4633072

2x  
302001

1x  
4504382

2x  
4549989

1x  
4558954

1x  
4521948

1x  
4616710

1x  
4654926

1x  
614101

2x  
4550017

2x  
4508215

1x  
4514342

1x  
4616581

1x  
4616578

1x  
4616588

1x  
4529234

1x  
241226

6x  
4516843

1x  
408326

1x  
4521947

2x  
4616576

2x  
4625234

2x  
302323

1x  
4144024

1x  
615726

3x  
3005740

2x  
4655080

1x  
4654923

1x  
4633693

1x  
302223

2x  
4282746

1x  
4562148

1x  
4616698

1x  
4654927

4x  
4655077

1x  
4654928

1x  
407026

1x  
614126

2x  
4121715



2x  
4567338



2x  
4616701



2x  
4620075



2x  
4626929

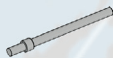

2x  
4538098



2x  
4278756



2x  
4210997



1x  
4222960



1x  
4211152



2x  
4617030



2x  
4620534



4x  
4211506



2x  
4211350



4x  
4626927



2x  
4261397



1x  
4211186



1x  
4616707



2x  
4620537



3x  
4211504



2x  
4211451



1x  
4212529



4x  
4657863



2x  
4221590



1x  
4620530



1x  
4654808



1x  
4211636



1x  
4654929



2x  
4211001



**Customer Service**  
**Kundenservice**  
**Service Consommateurs**  
**Servicio Al Consumidor**  
[www.lego.com/service](http://www.lego.com/service) or dial



00800 5346 5555 :

1-800-422-5346 :



1x  
4613134



2x  
4211535



3x  
3005741



3x  
4211043



1x  
4620079



2x  
4211397



1x  
4632574



1x  
4523398



1x  
4243797



1x  
4520320



4x  
4211119



2x  
4560177



2011



8639



8423, 8639, 8679



8426



8487



8200, 8487



8487



8206, 8484, 8679



8206, 8679



8487



8424



8639



8423, 8679



8638



8638



8487



8638



8638



8638

2011



8201, 8487



8639



8639



8486



8426, 8639



8639



8426



8638



8486



8679



8679



8679



8679



8424

2012



9486



9485



9486



9481



9480



9483



9484



9485



9479



9484



9486



9483



9486



9485



9486



9485



9478





Go to [www.LEGOsurvey.com/product](http://www.LEGOsurvey.com/product)  
to fill out a survey for a chance  
to win a cool LEGO® Product.

No purchase necessary.

Open to all residents where not prohibited.

[www.LEGOsurvey.com/product](http://www.LEGOsurvey.com/product)

**GEWINNE!**

Nimm an der Umfrage auf  
[www.LEGOsurvey.com/product](http://www.LEGOsurvey.com/product)  
teil und hab die Chance ein cooles  
LEGO® Produkt zu gewinnen!  
Die Teilnahme am Gewinnspiel führt zu keinerlei  
Kaufverpflichtungen. Teilnahme in allen nicht  
ausgeschlossenen Ländern möglich.

**WIN!**

Ga naar [www.LEGOsurvey.com/product](http://www.LEGOsurvey.com/product),  
vul een enquêteformulier  
in en maak kans op een  
cool LEGO® product.  
Geen aankoopverplichting.  
Iedereen mag deelnemen, uitgezonderd  
ingezetenden van landen waar een  
enquêteverbod geldt.

**GAGNE !**

Visite [www.LEGOsurvey.com/product](http://www.LEGOsurvey.com/product)  
pour répondre à un  
questionnaire et avoir une  
chance de gagner un produit  
LEGO® très cool !  
Aucune obligation d'achat.  
Ouvert à tous les résidents des pays  
autorisés.

**当てよう!**

[www.LEGOsurvey.com/product](http://www.LEGOsurvey.com/product)  
にアクセスして、  
アンケートにご記入ください。  
当選者にはレゴ®製品を  
差し上げます。  
お買い上げの必要はありません。  
禁止されていない限り、すべての皆様にご利用いただけます。



[www.LEGO.com](http://www.LEGO.com)

6003658

LEGO and the LEGO logo are trademarks of the LEGO Group. ©2012 The LEGO Group. © Disney/Pixar