

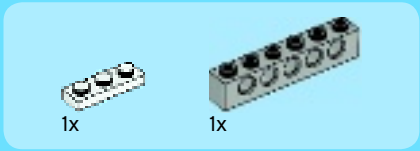

CREATOR

7347

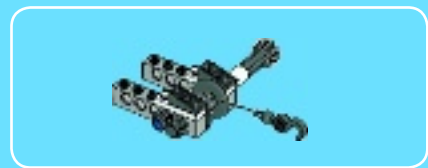



1

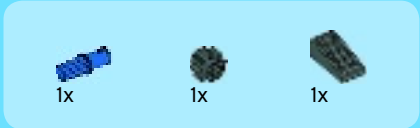
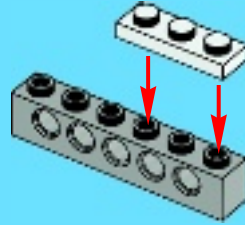

2

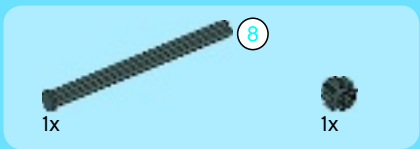
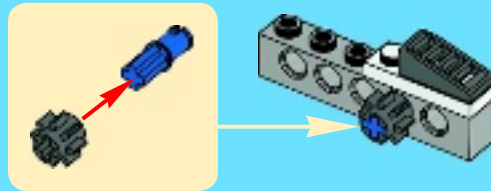

3

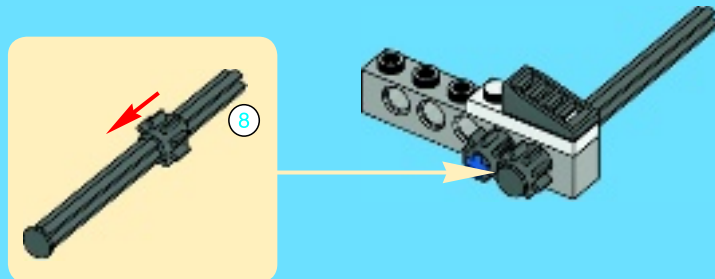

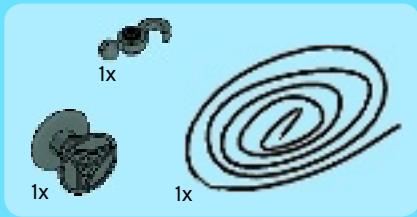

4

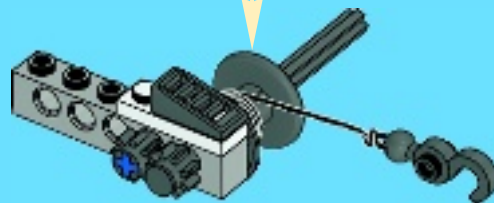
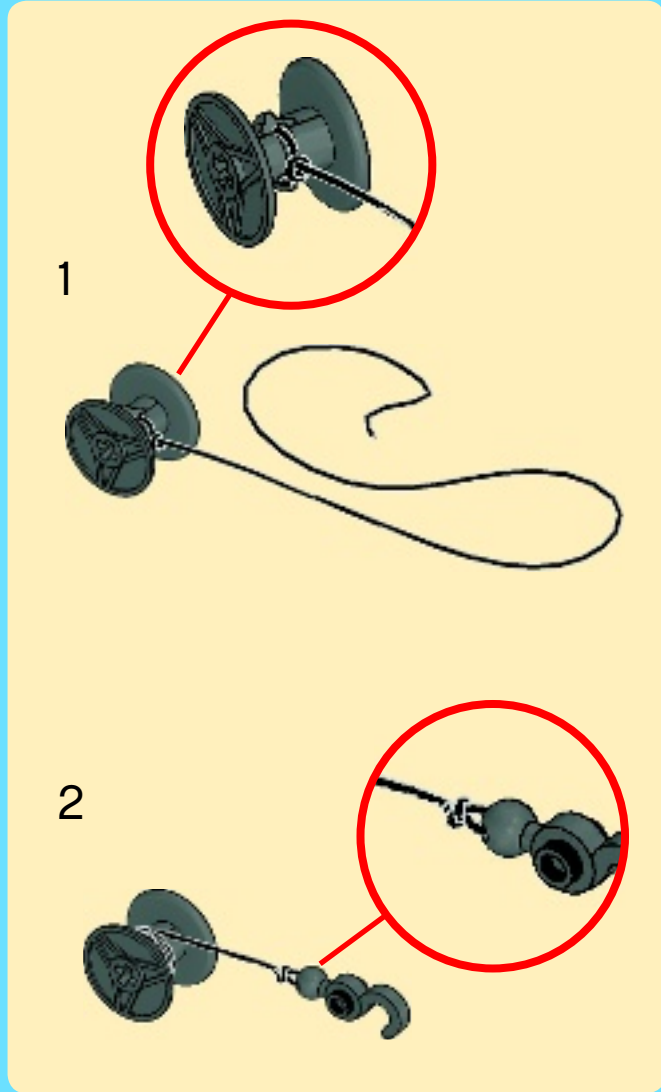

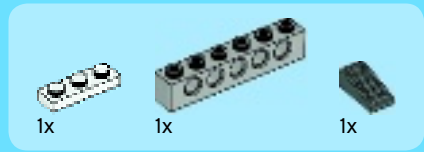

5

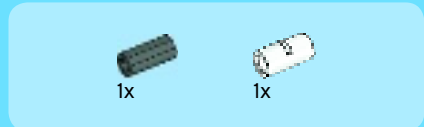
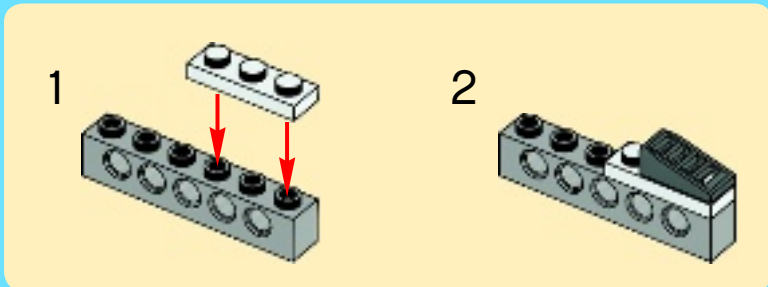

6

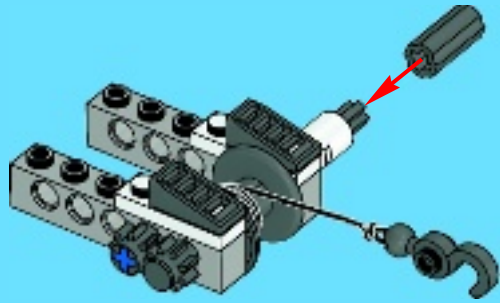



1x



1x

7

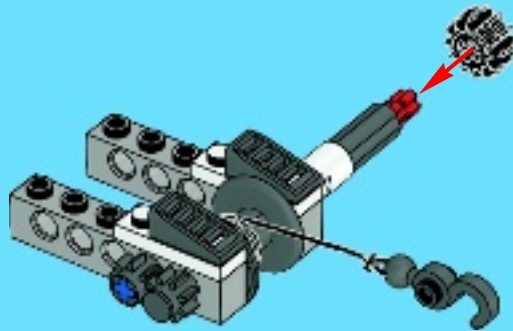

38

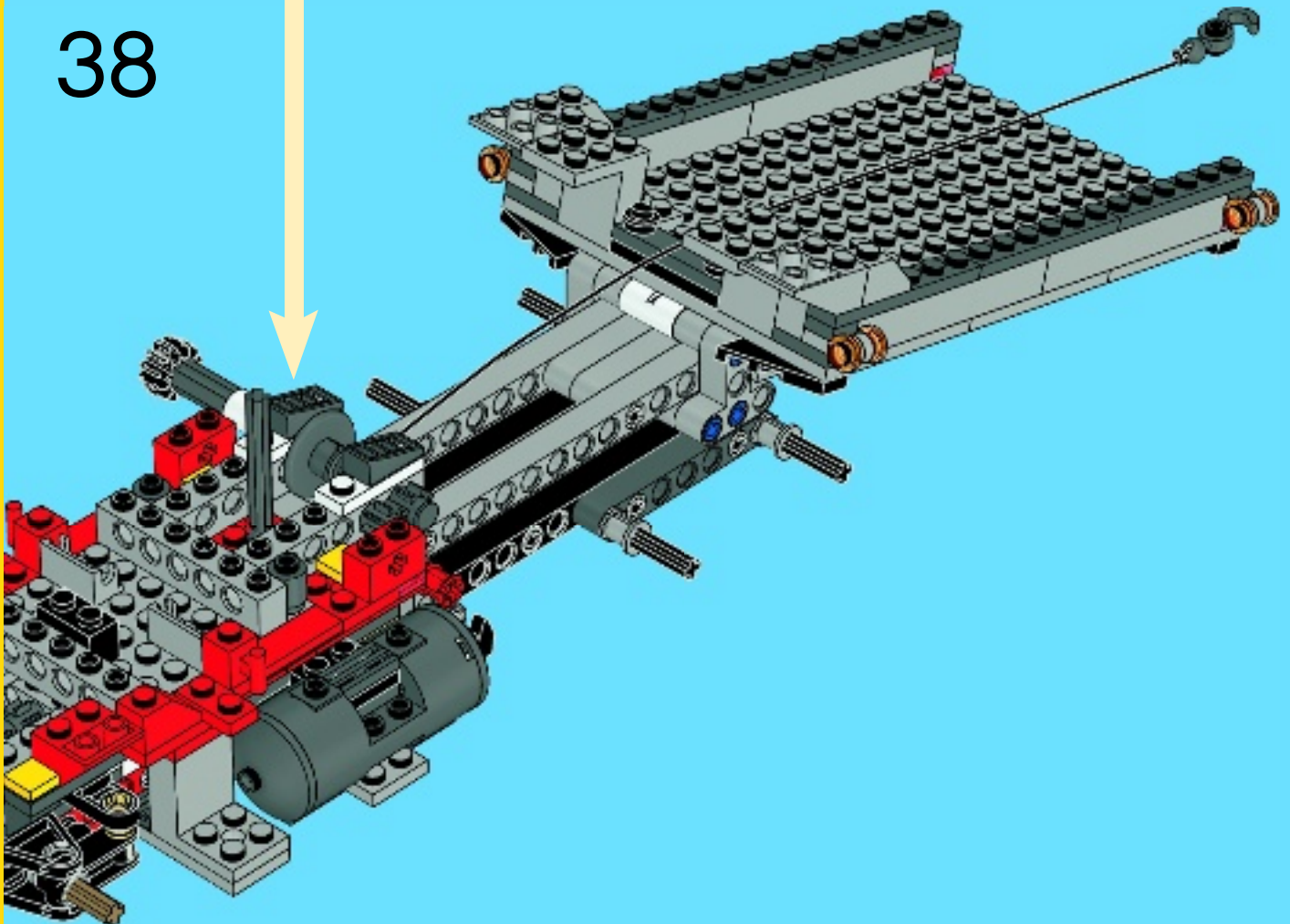

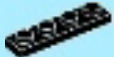

1x



2x

39

1



2

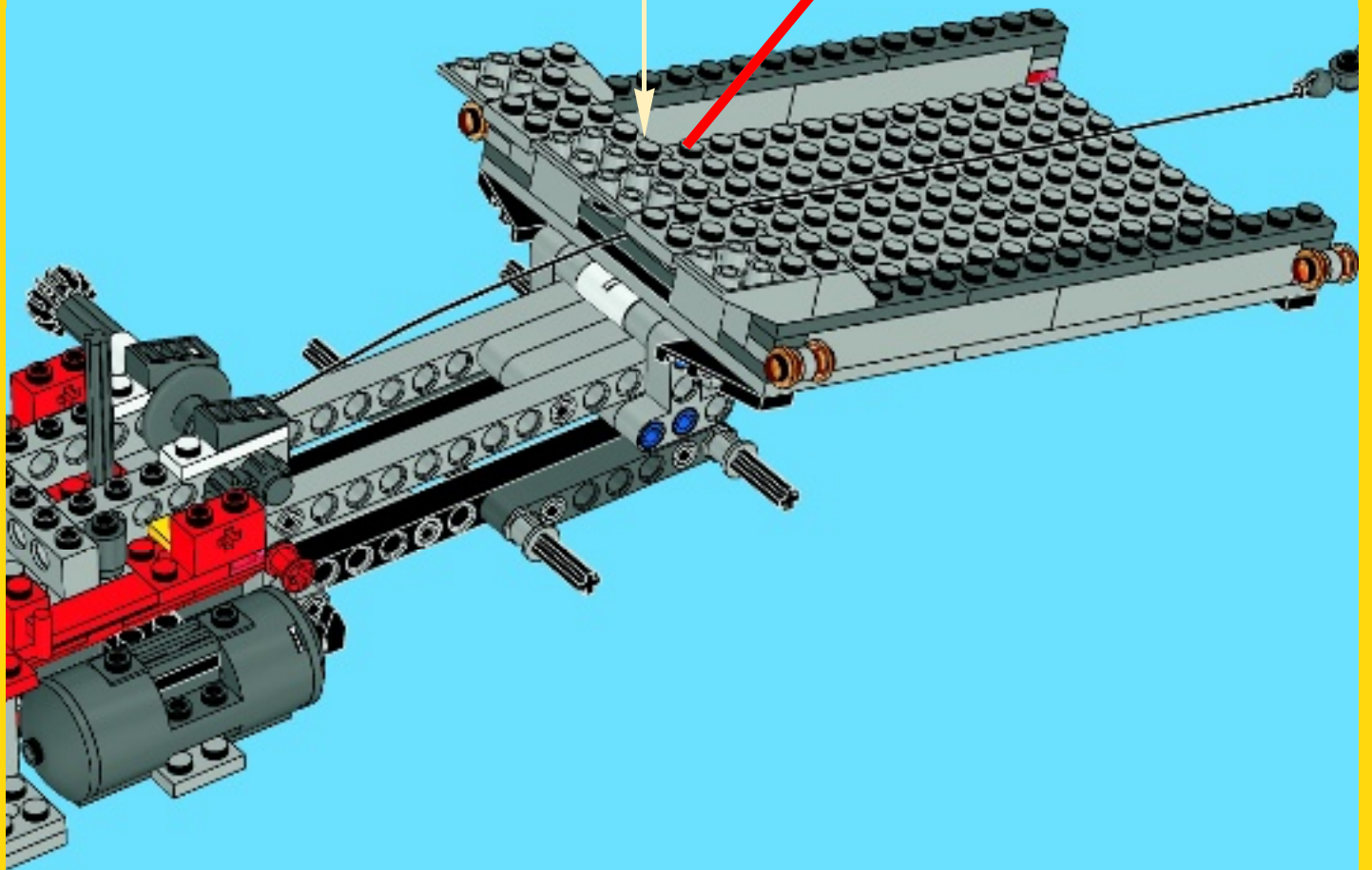
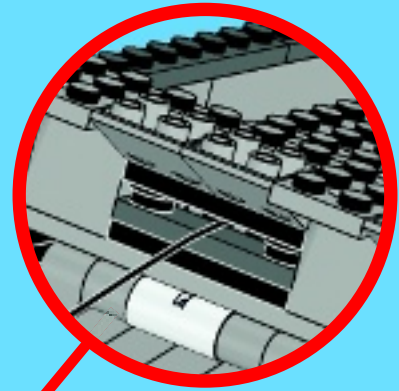
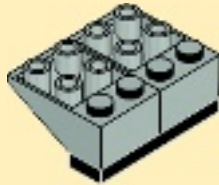

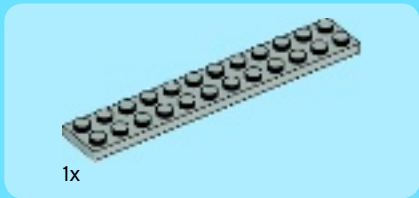

1x

40

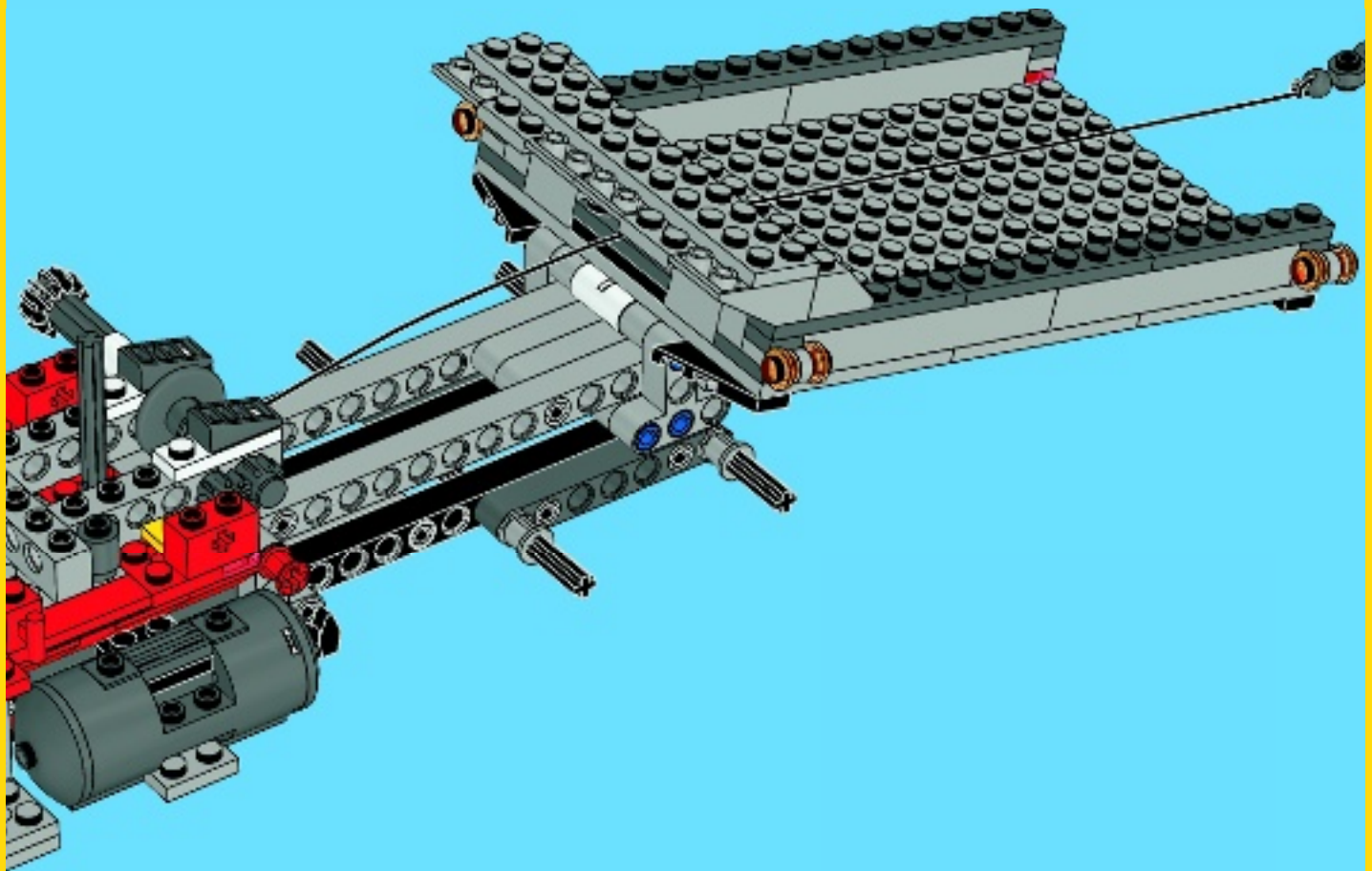



2x



1x

41

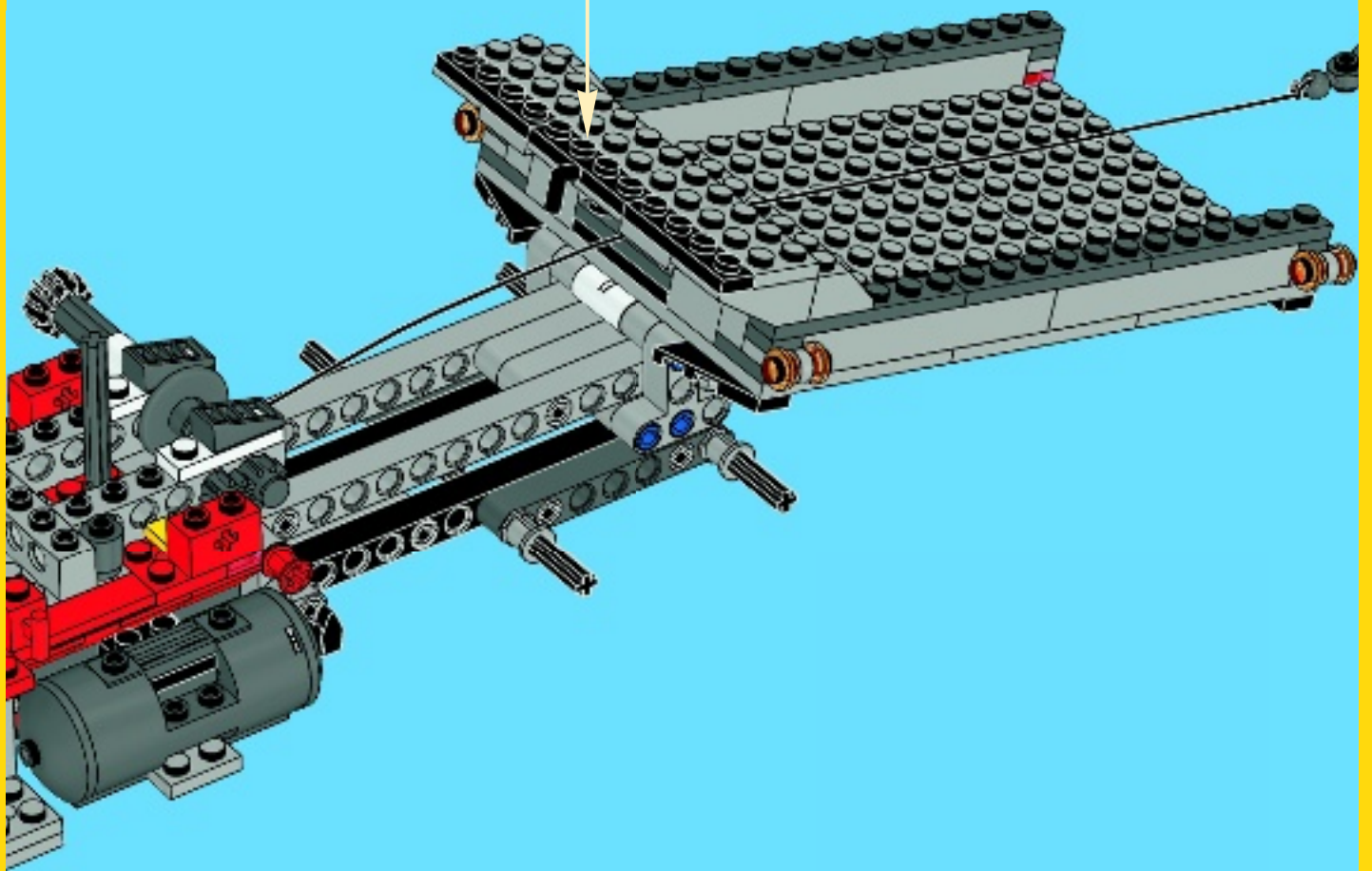



1x



2x



2x

42

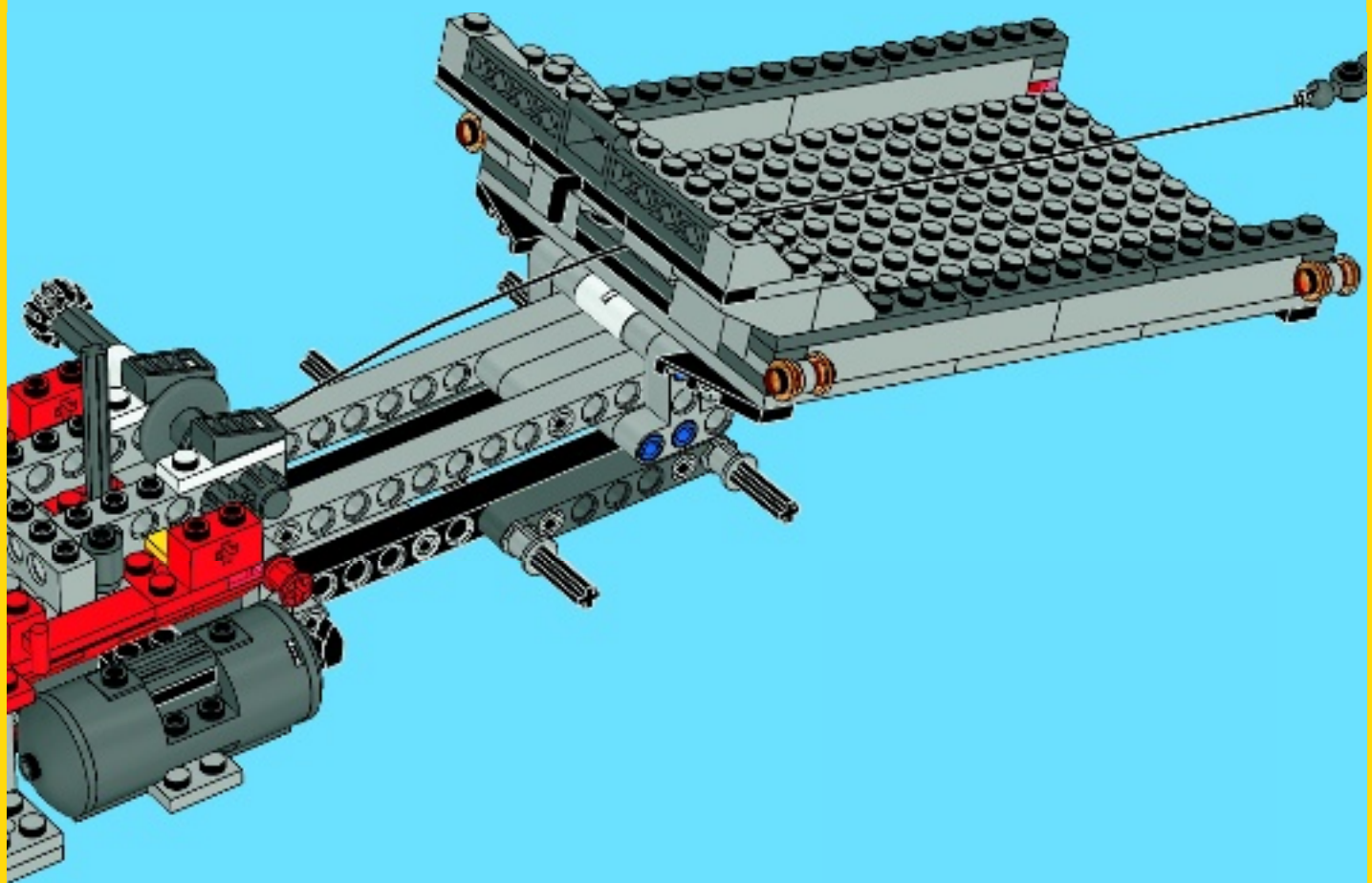



1x



2x



2x

43

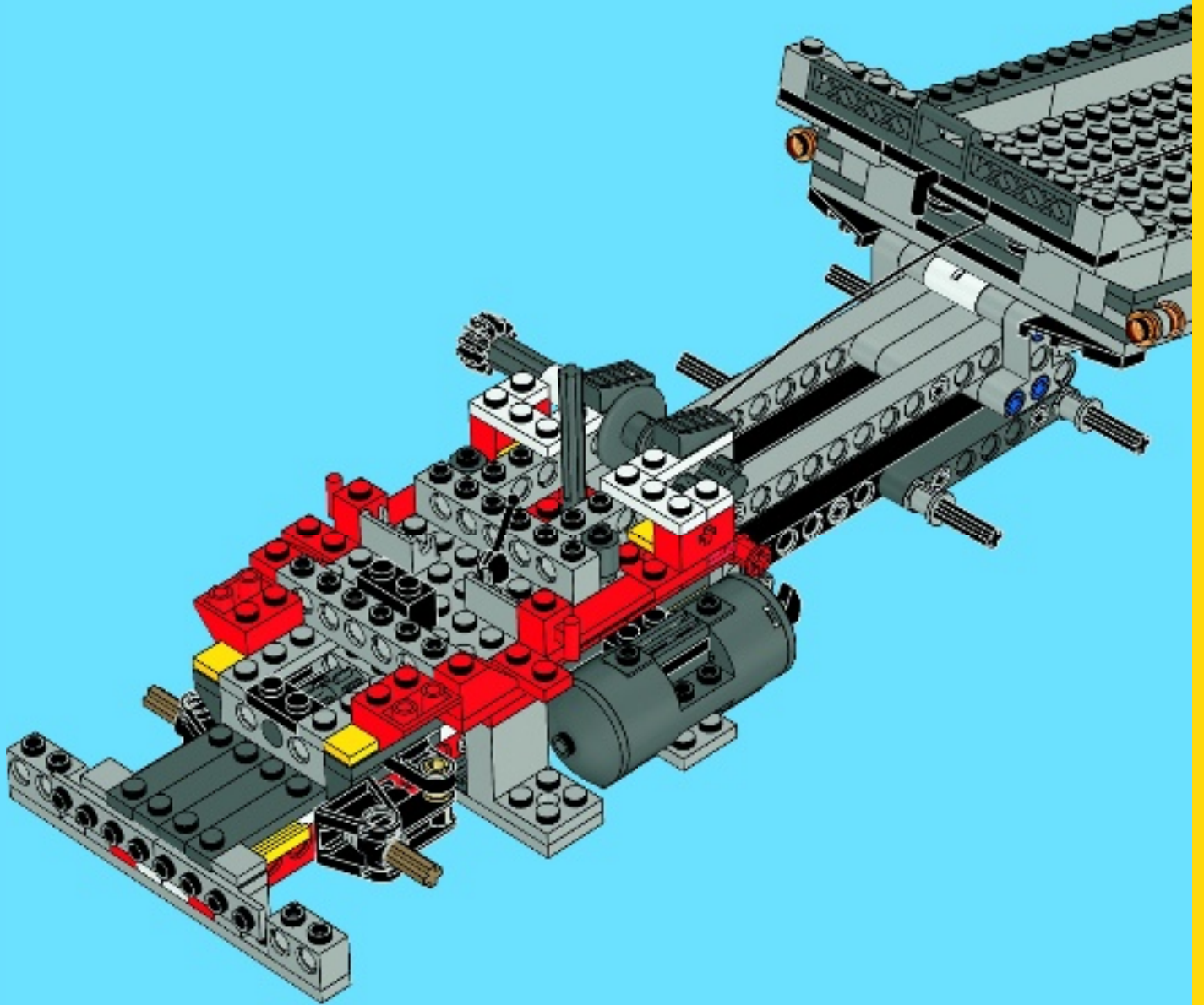

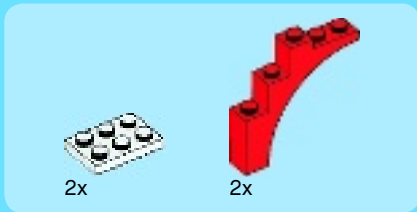

44

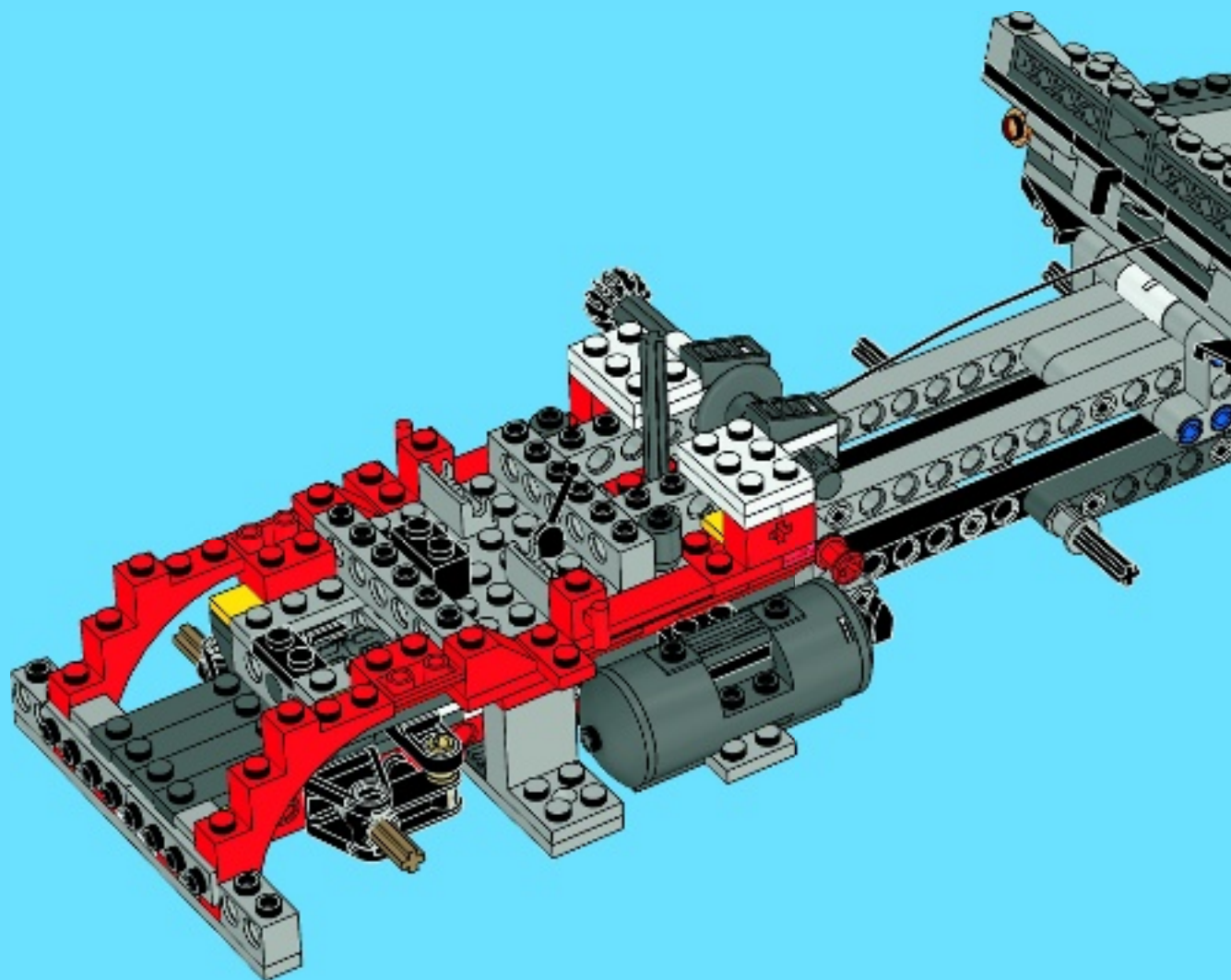



4x



1x



2x

45

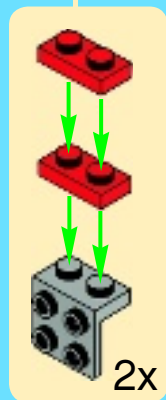
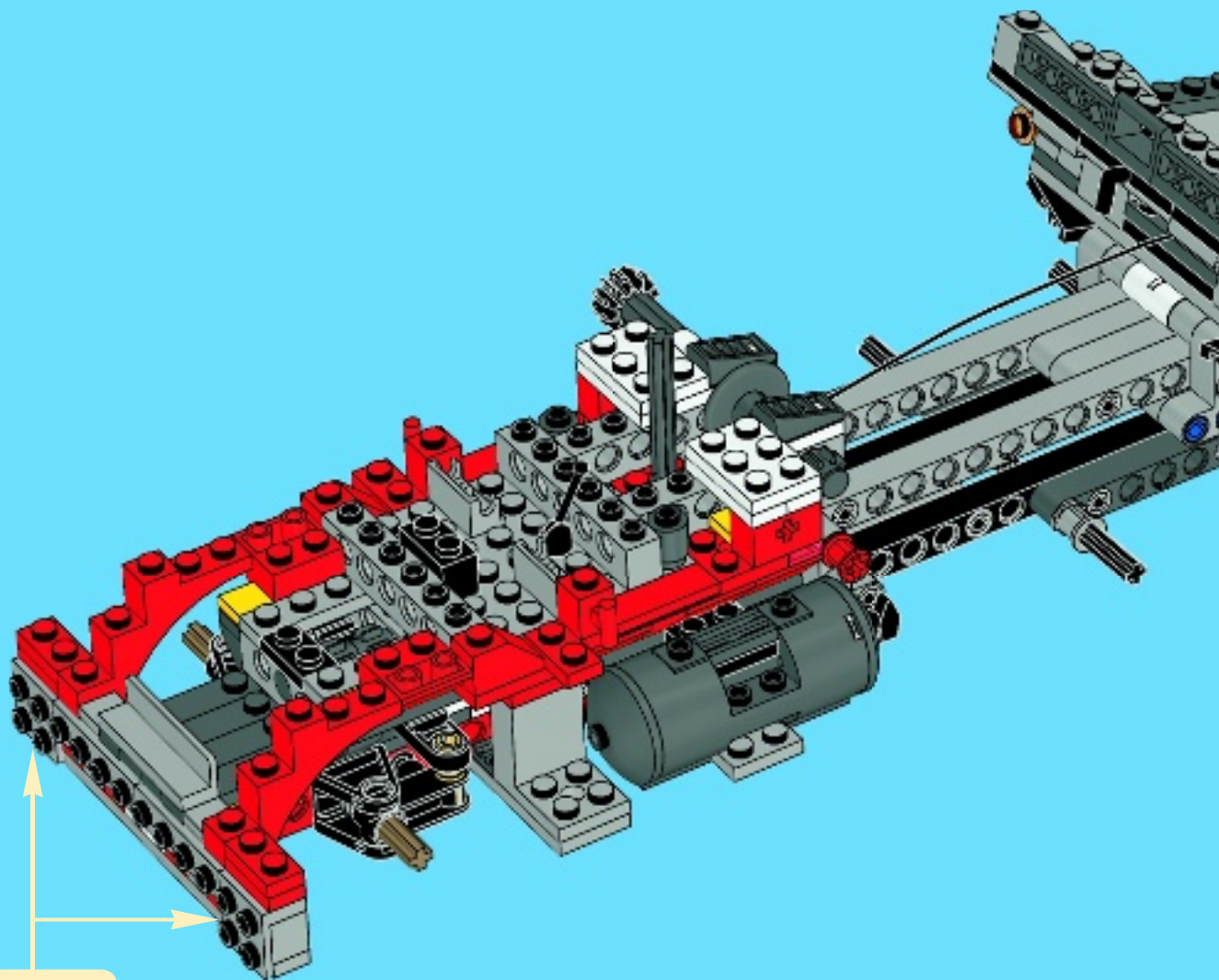

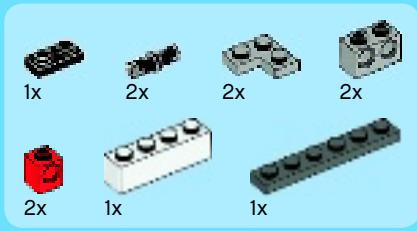

46

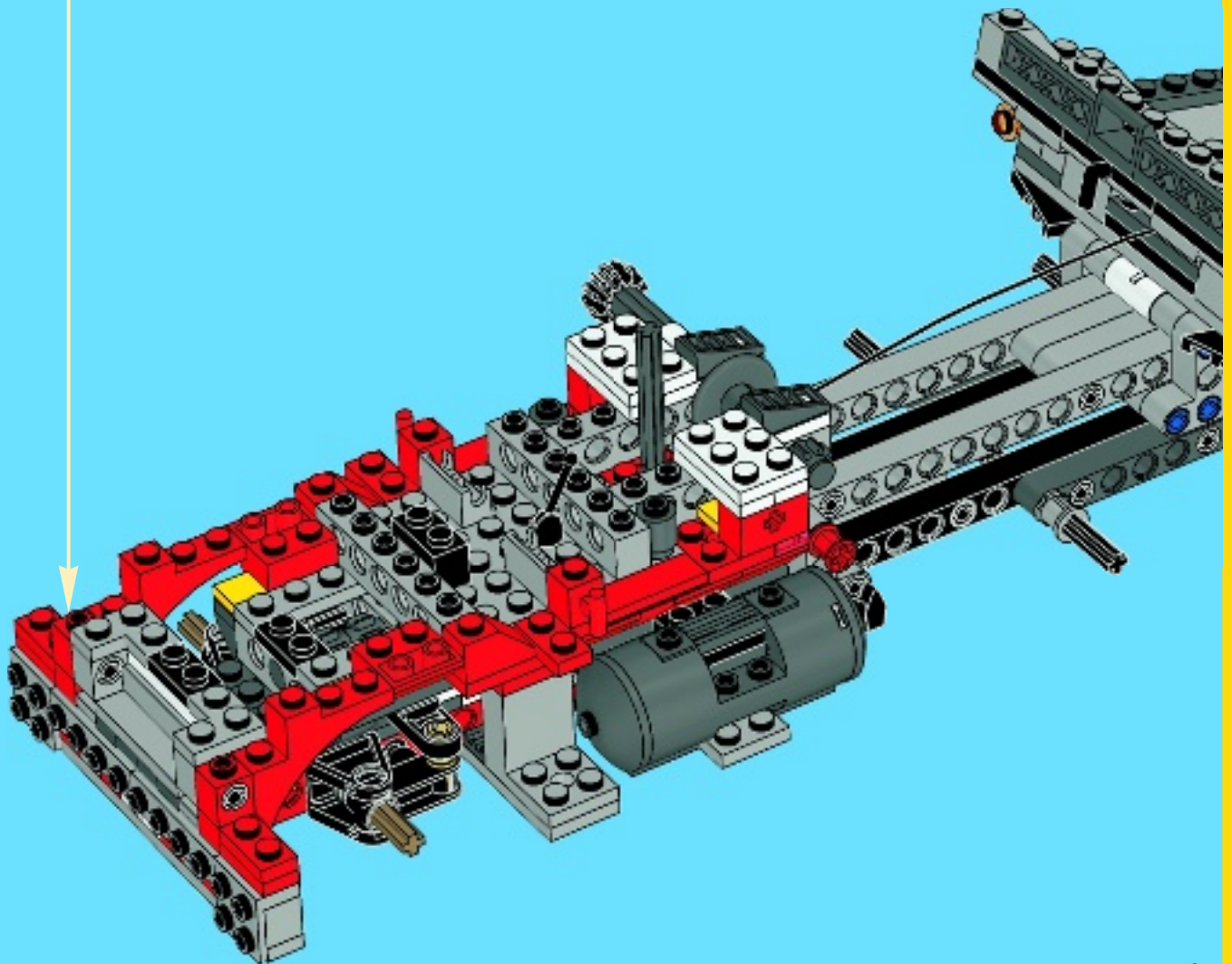
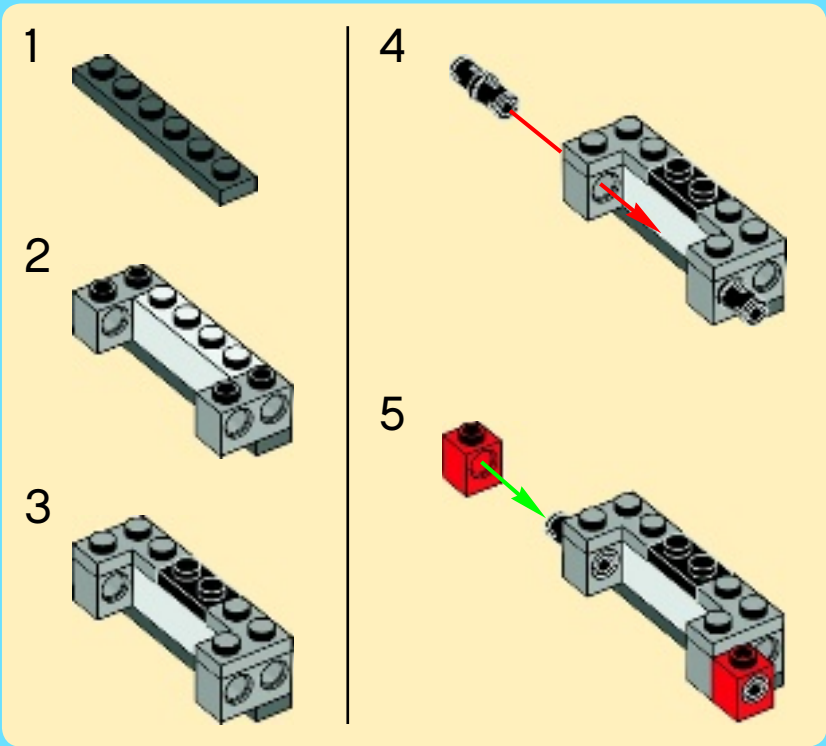



2x



2x



2x

47

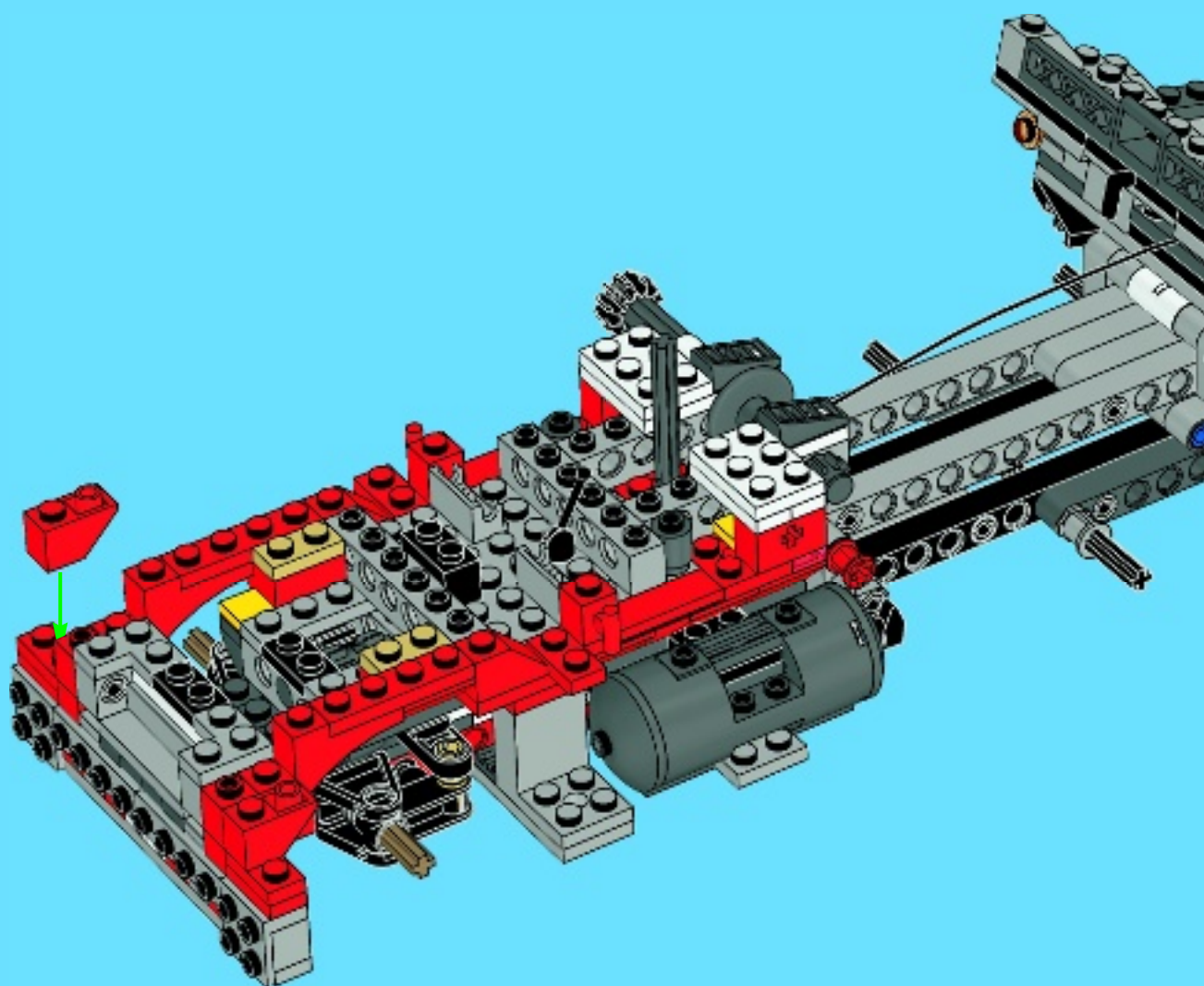



2x



4x



2x

48

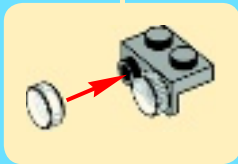
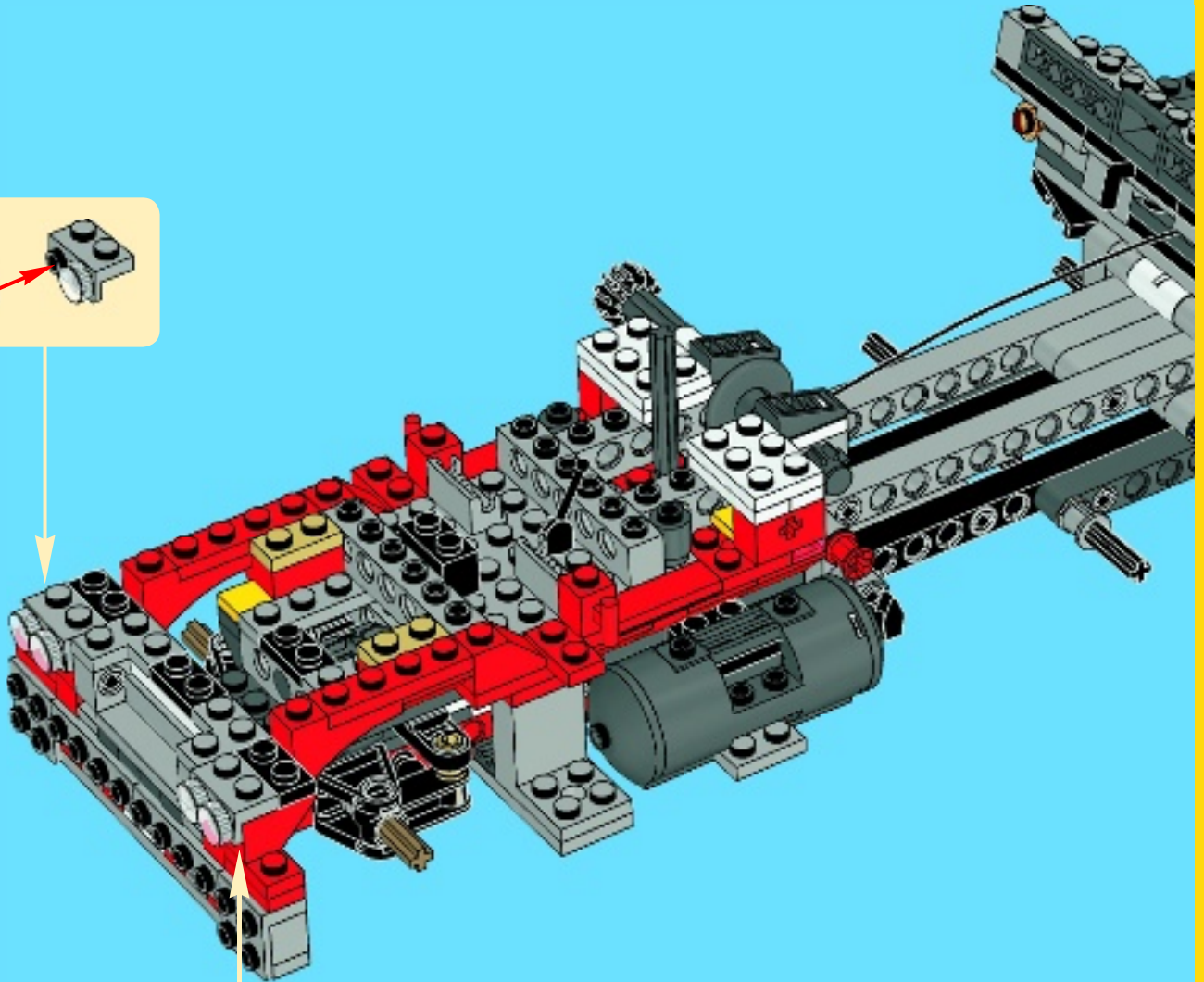
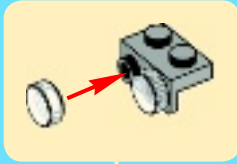

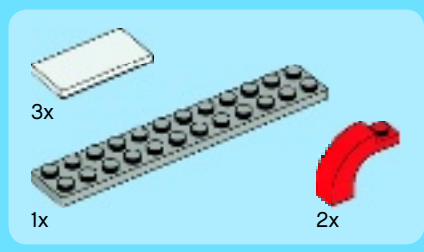

49

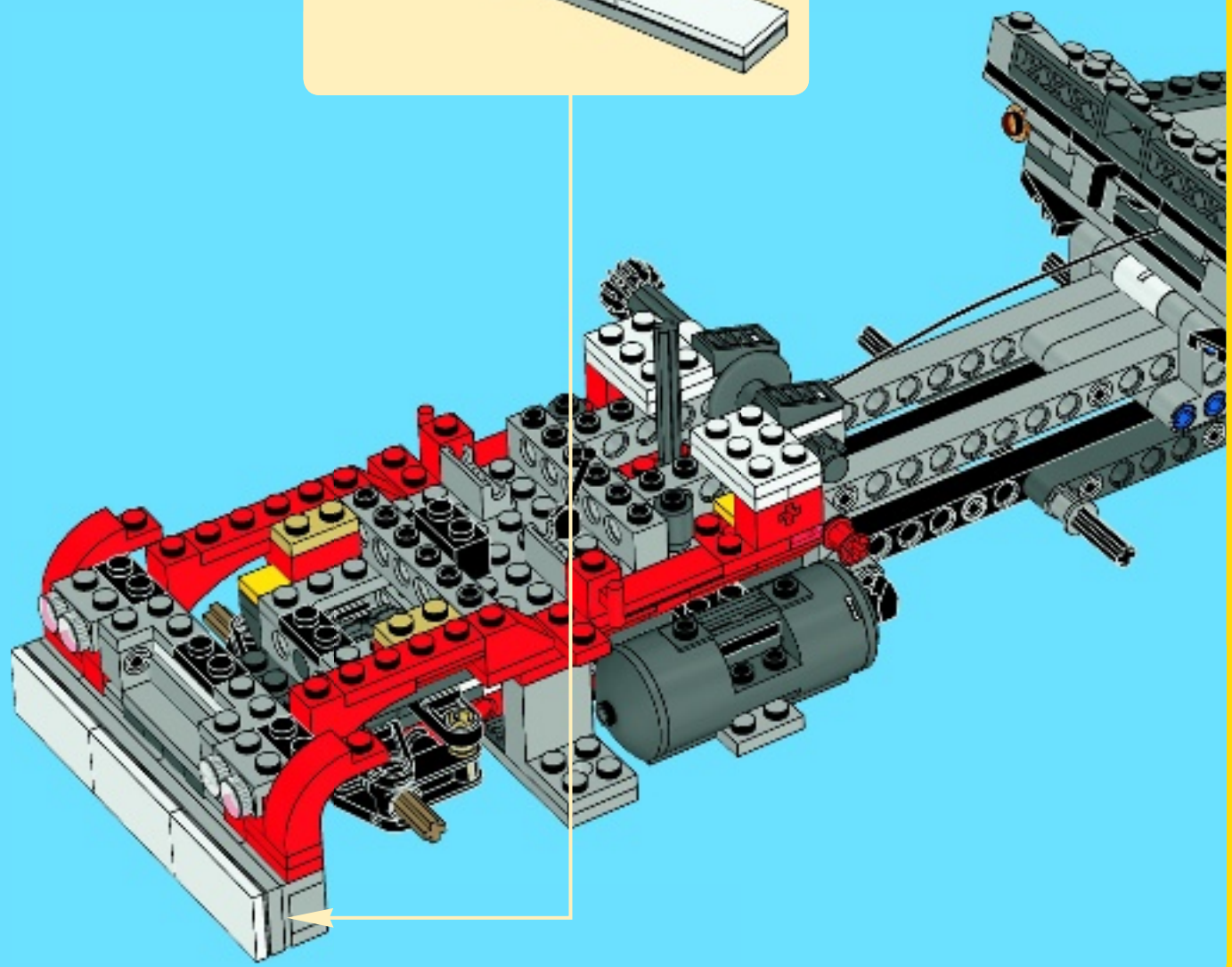
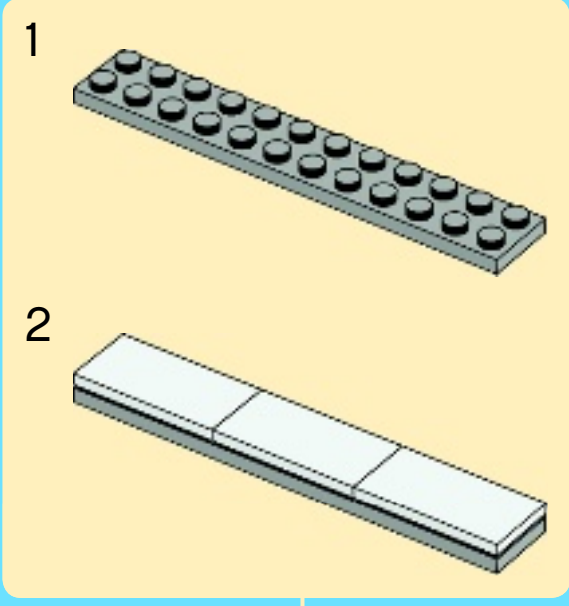

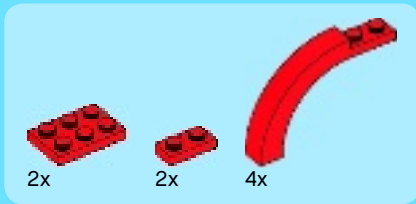

50

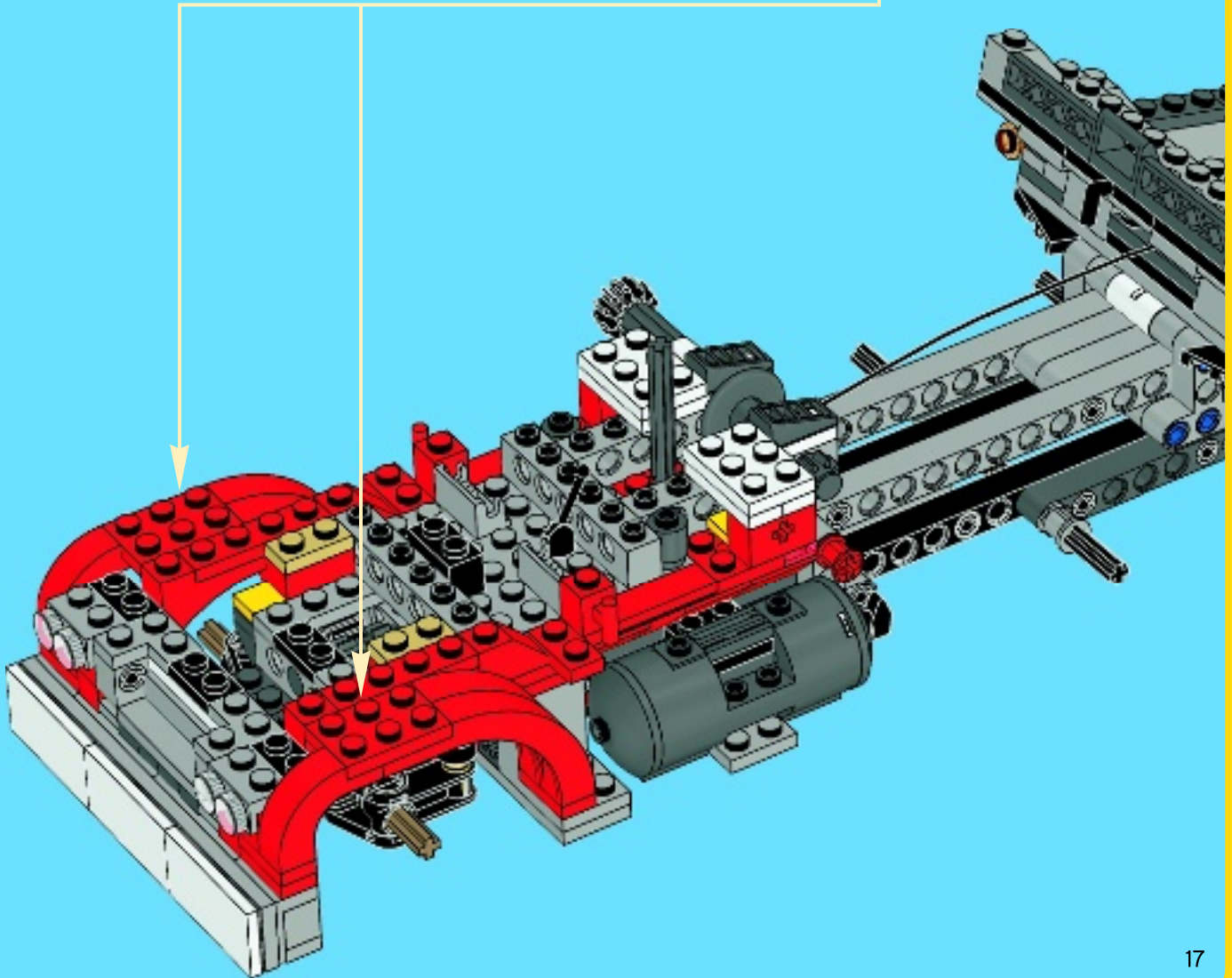
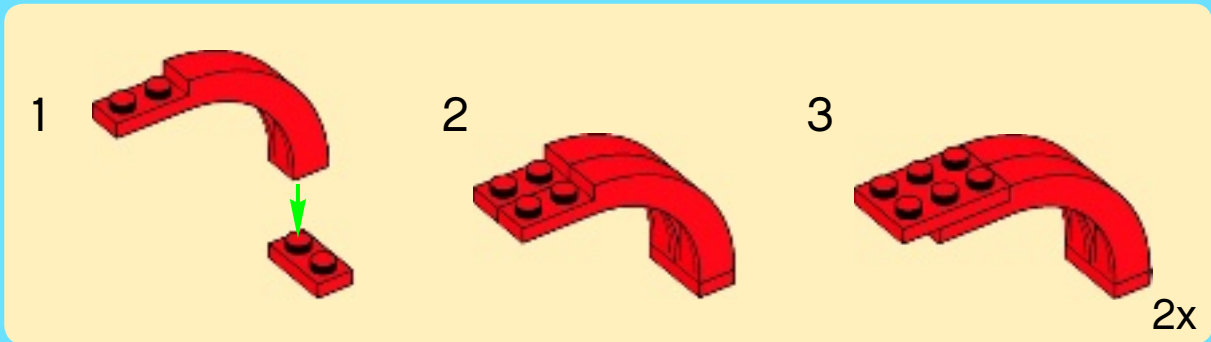



2x



6x



2x

51

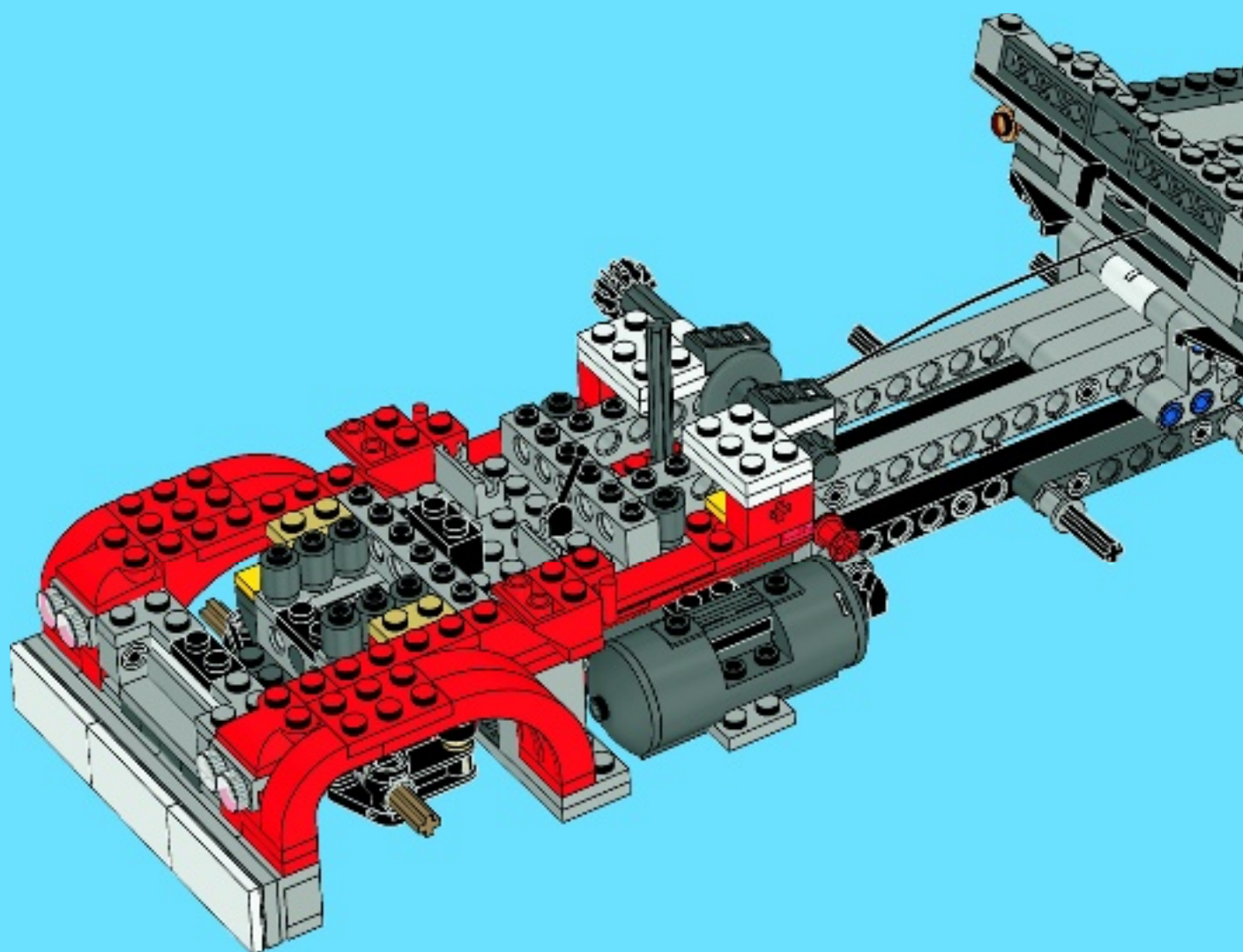



52

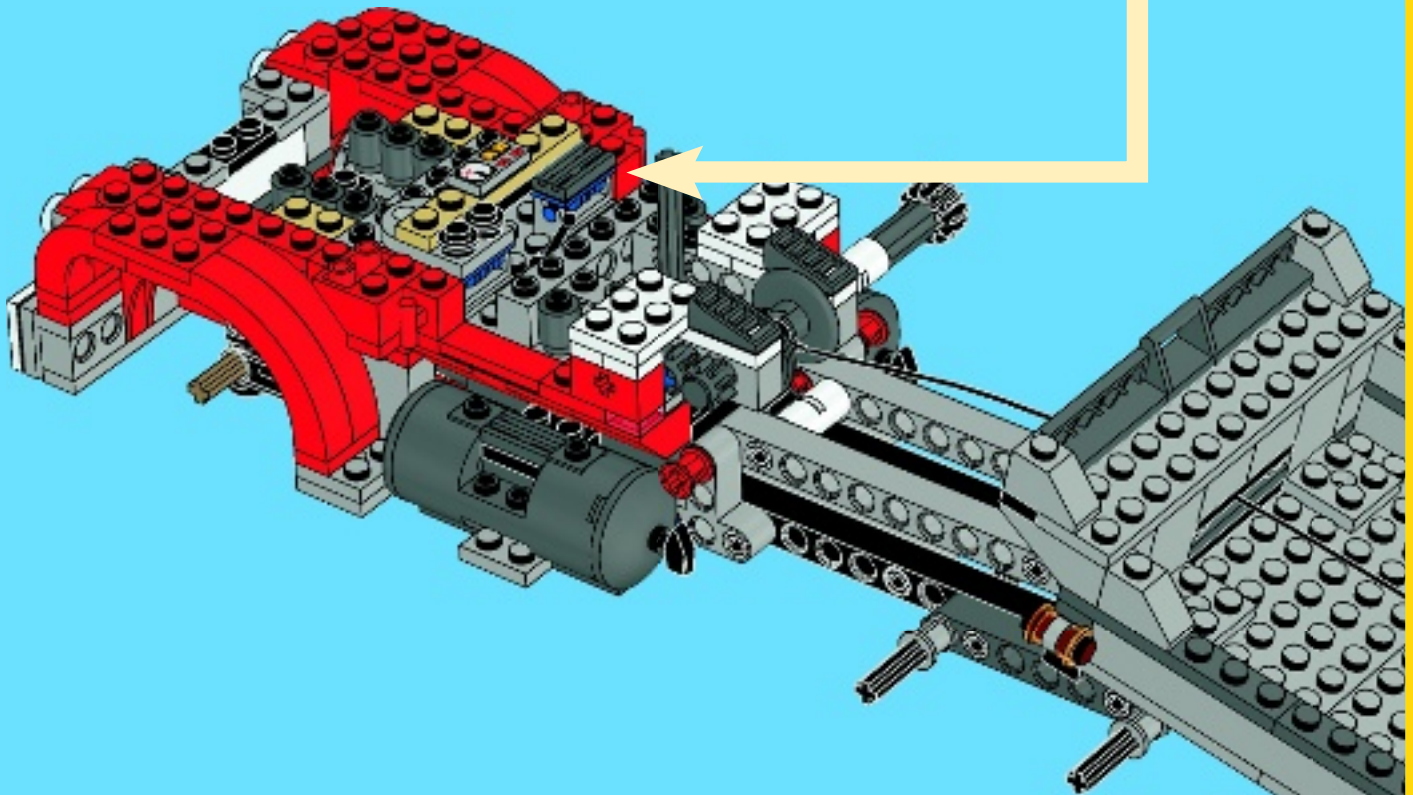
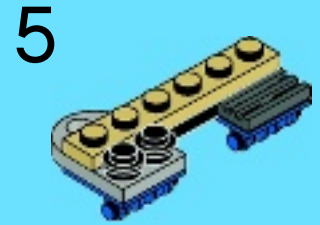
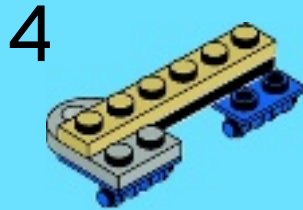
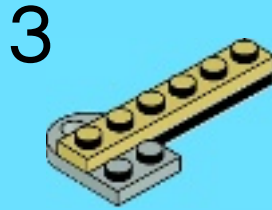
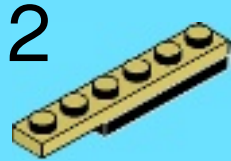
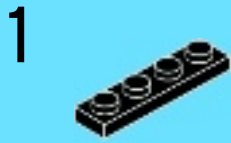



2x



2x



2x



2x

53

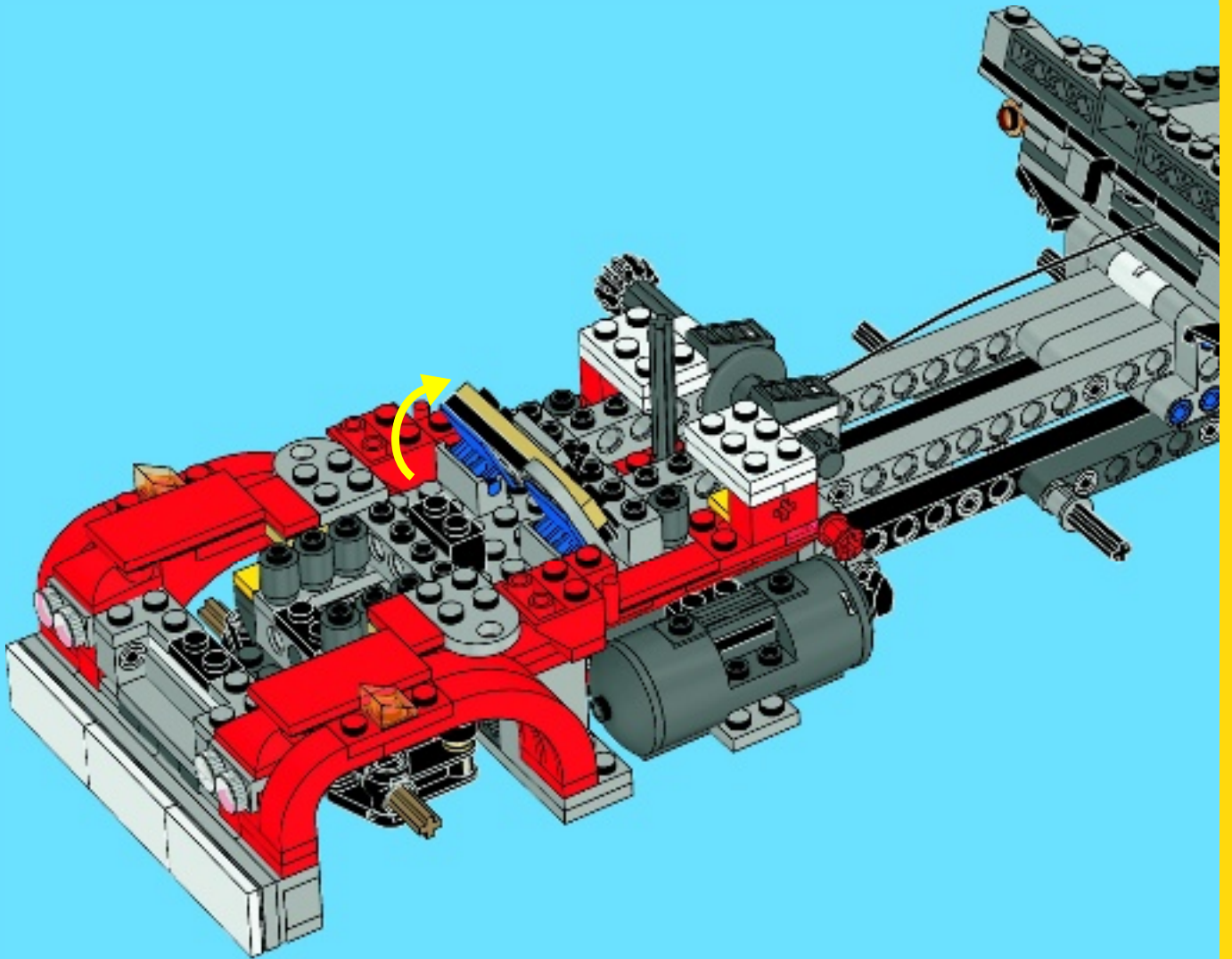

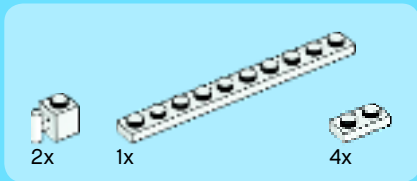

54

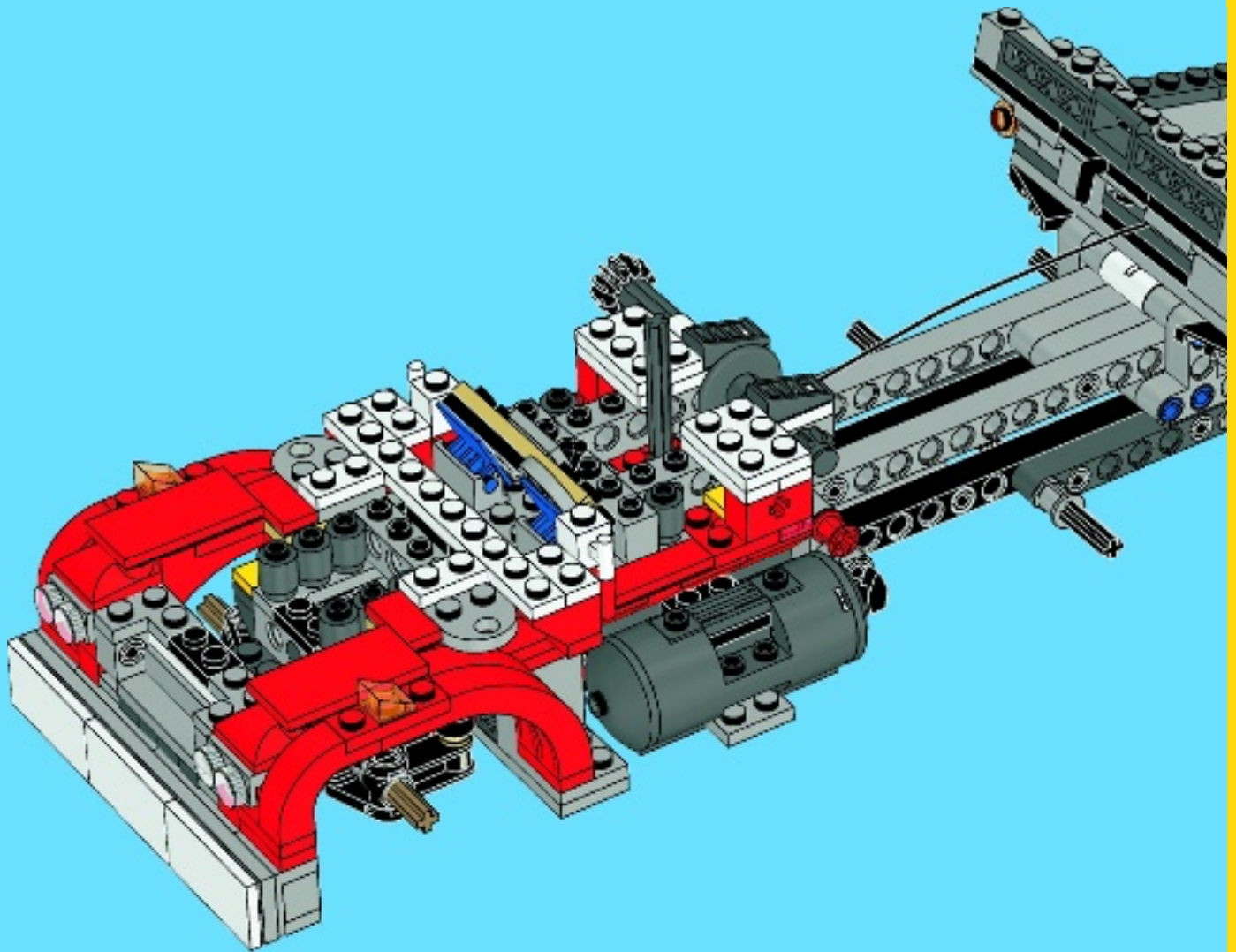

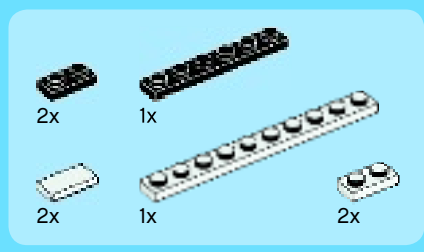

55

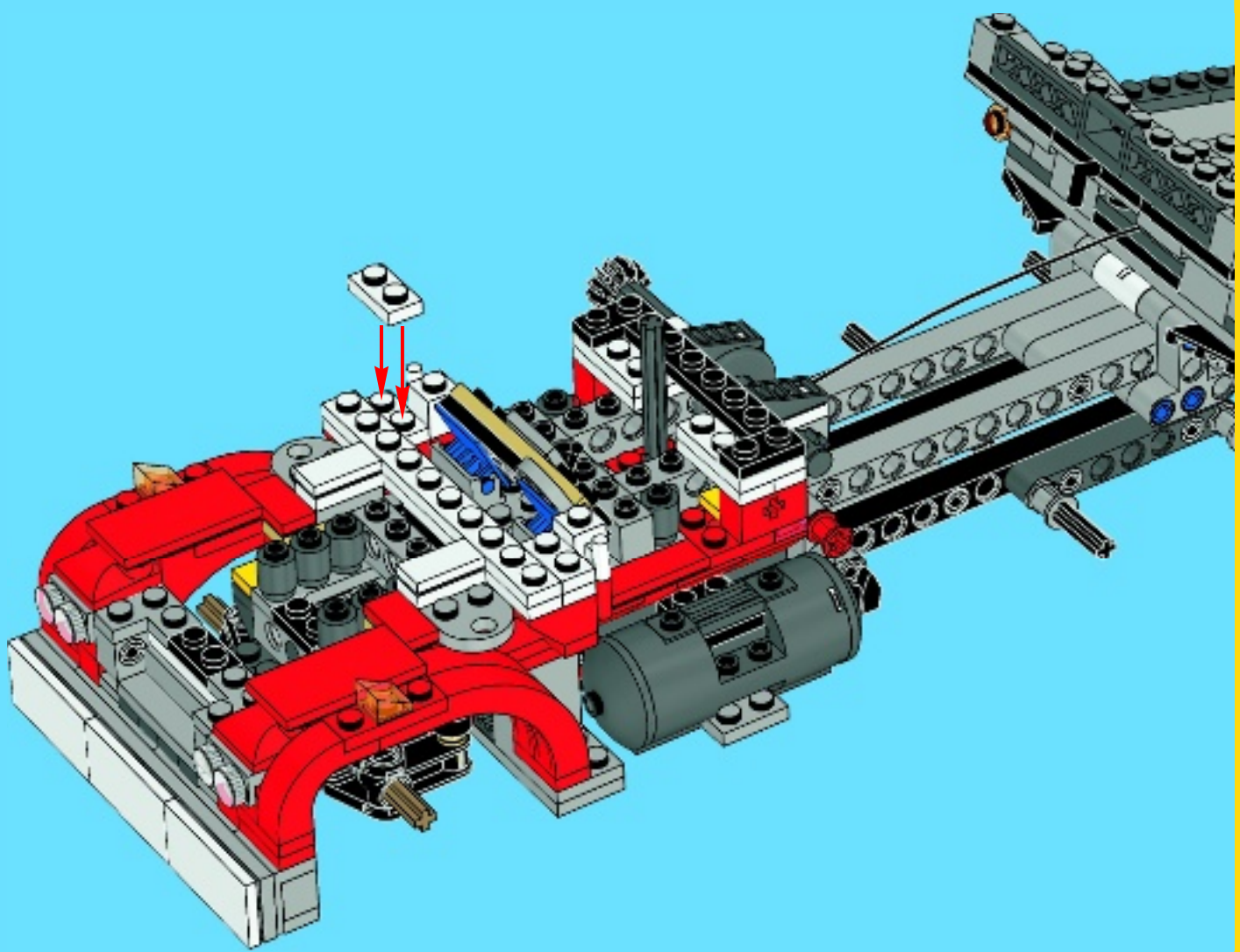



4x



2x



1x



1x

56

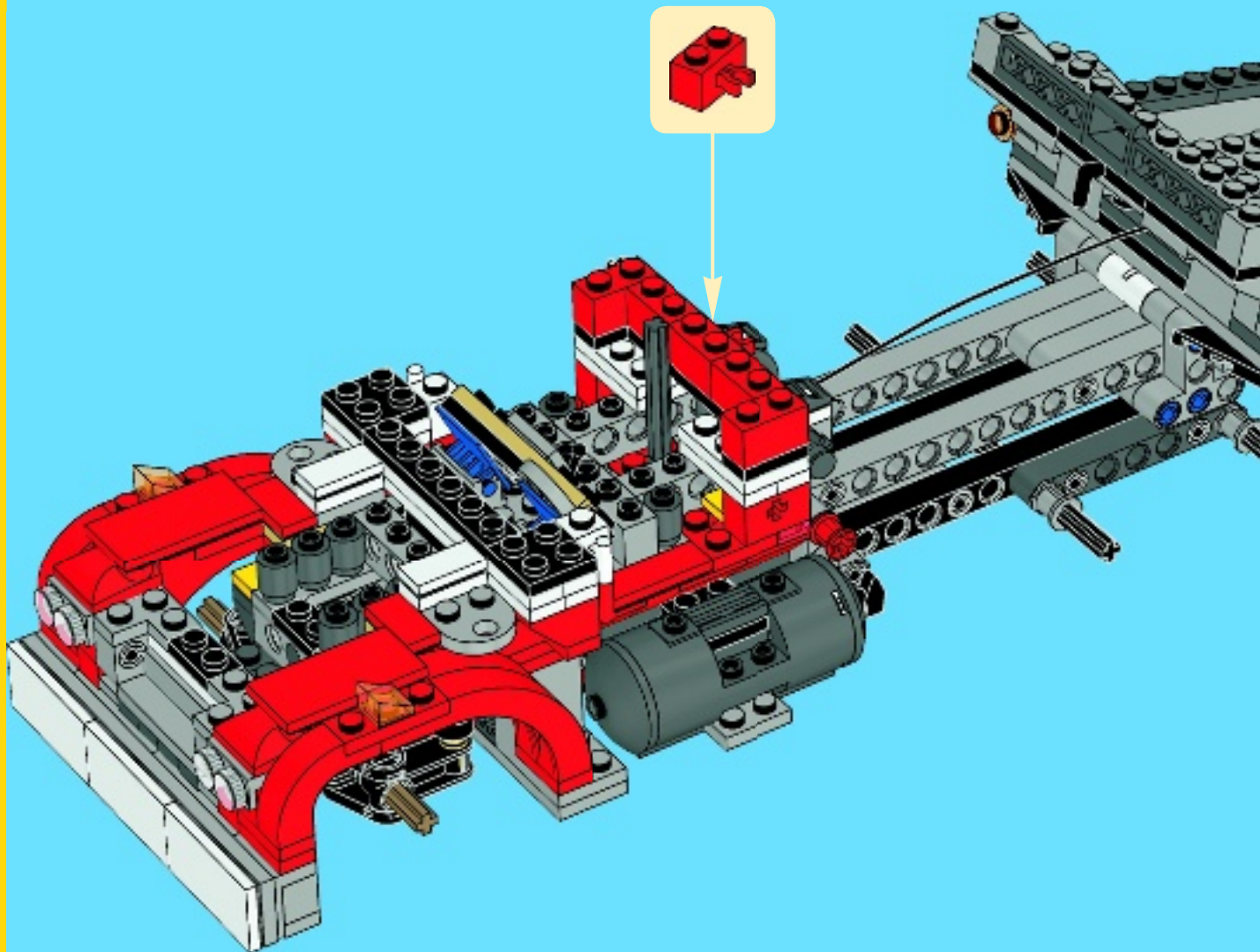

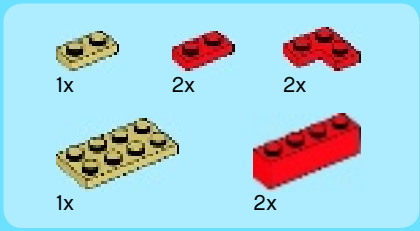

57

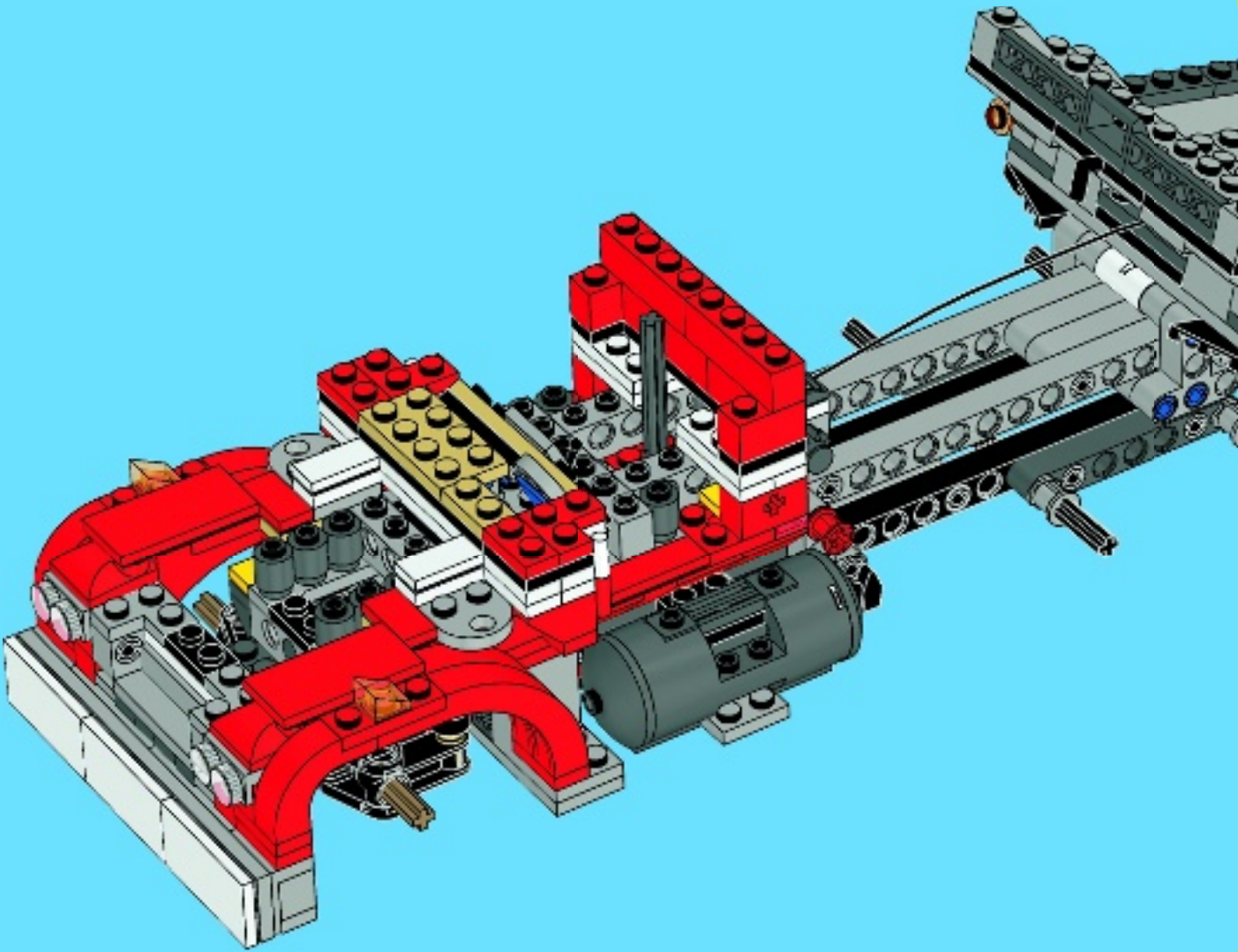

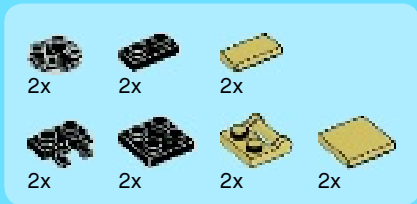

58

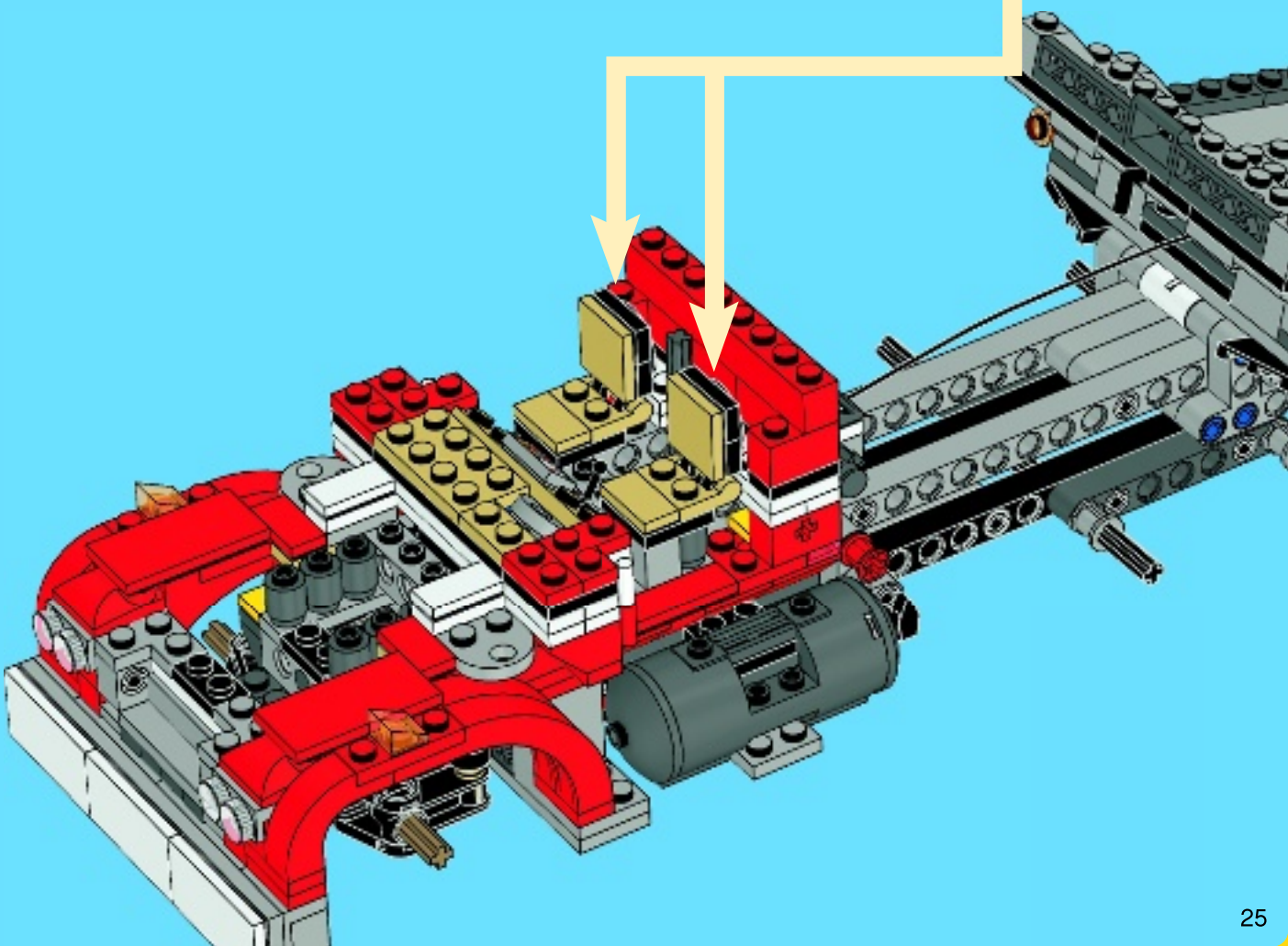
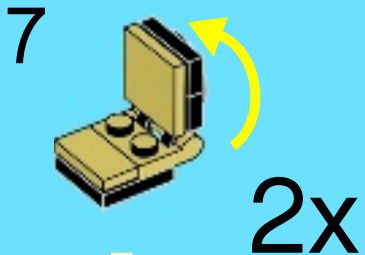
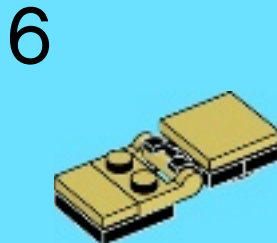
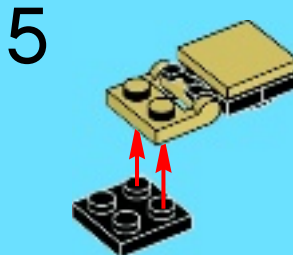
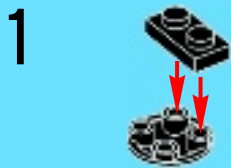

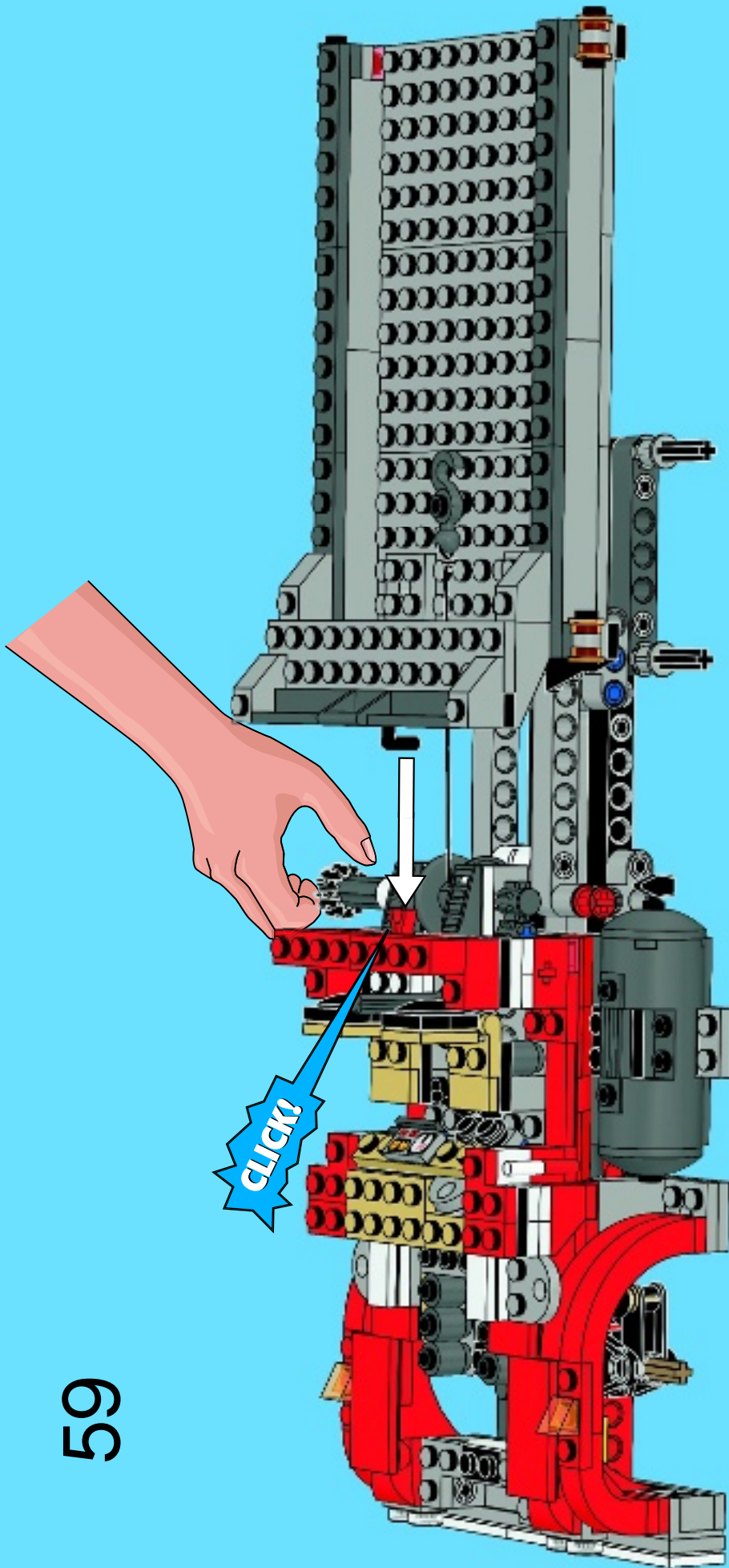

59



1

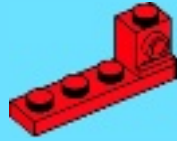

2

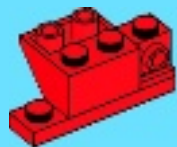

3

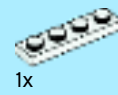
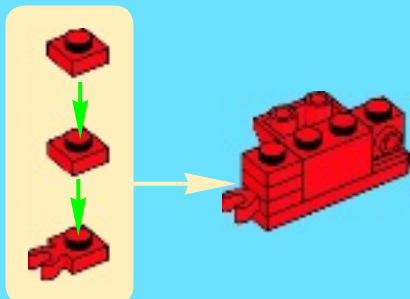

1x

4



2x



1x



1x

5



1x



1x



1x

6

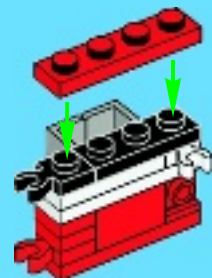



1x



1x



1x

7

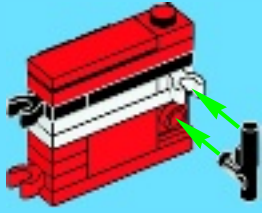

1x

8

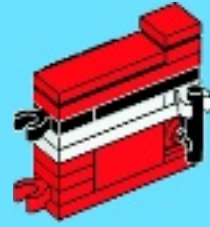

60

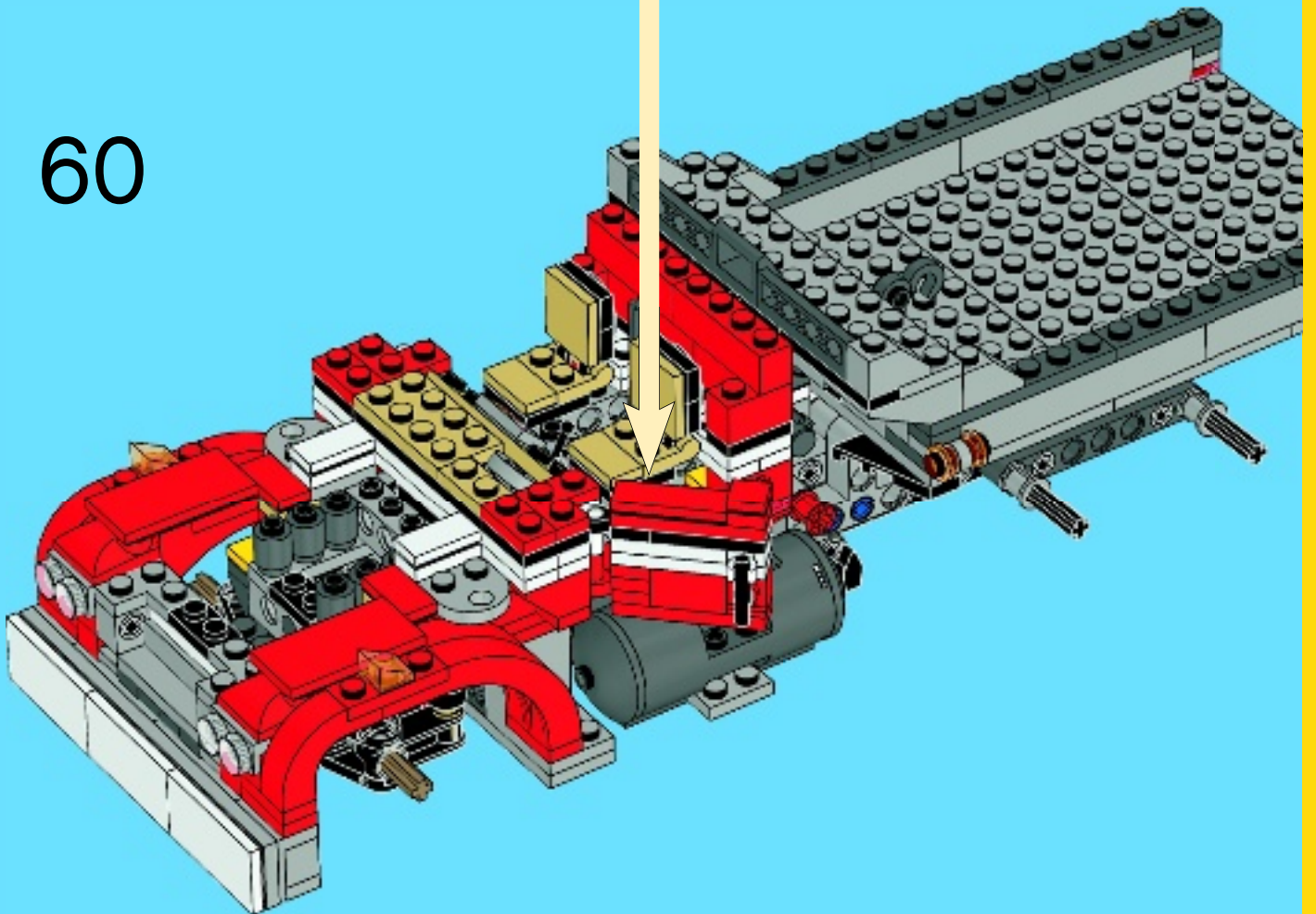



1

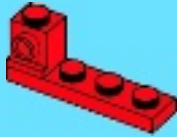

2

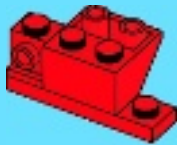

3

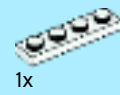
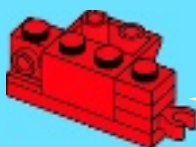
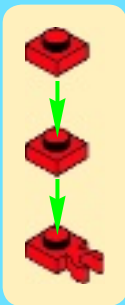

1x

4

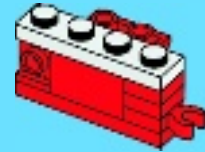

2x

1x

1x

5



1x

1x

1x

6

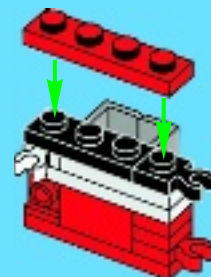



1x



1x



1x

7

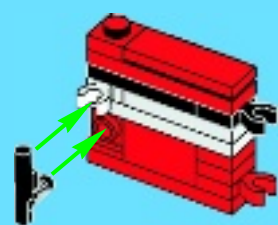

1x

8

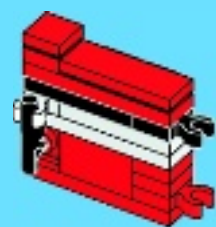

61

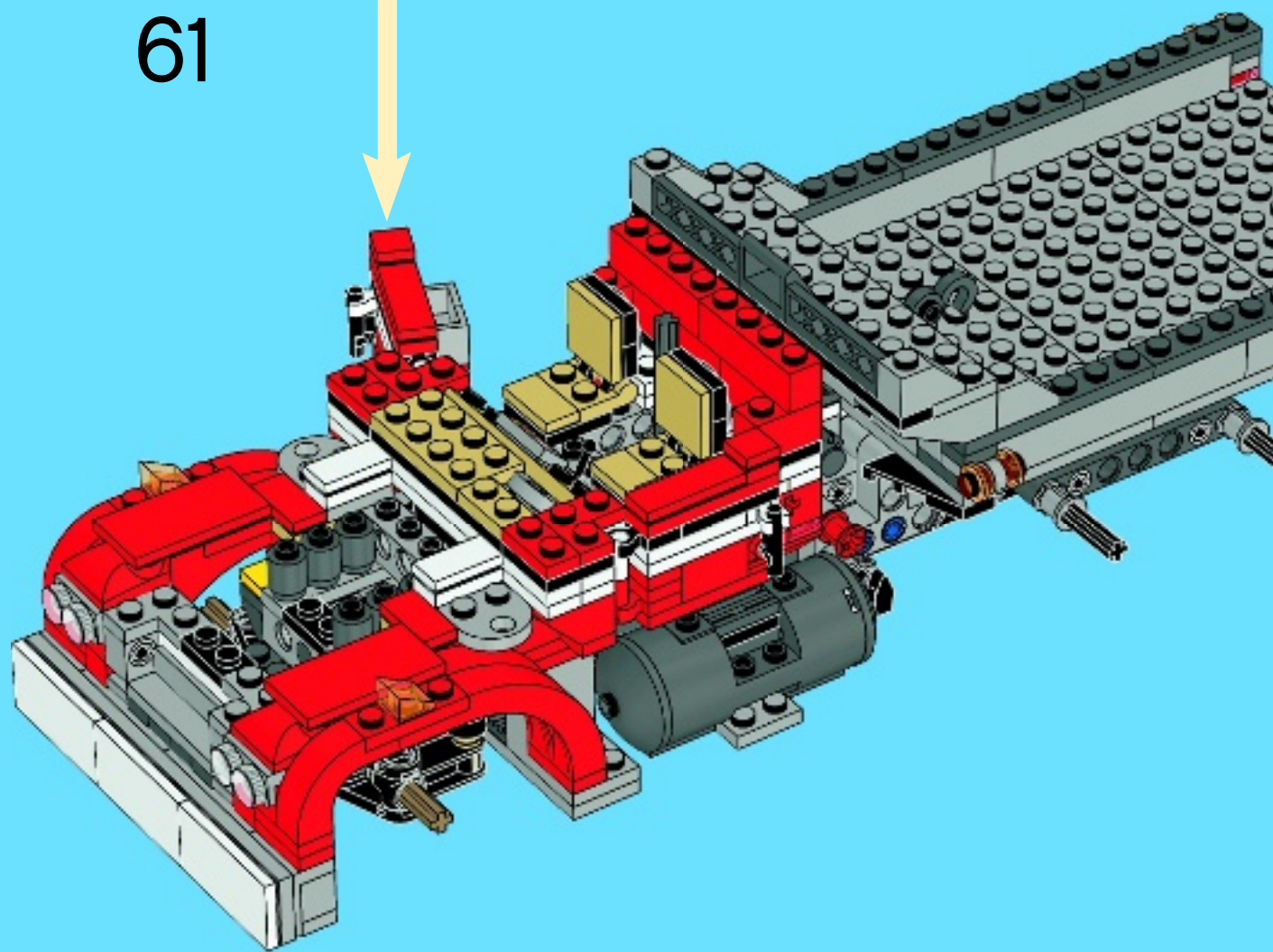

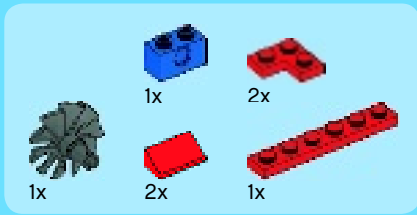

62

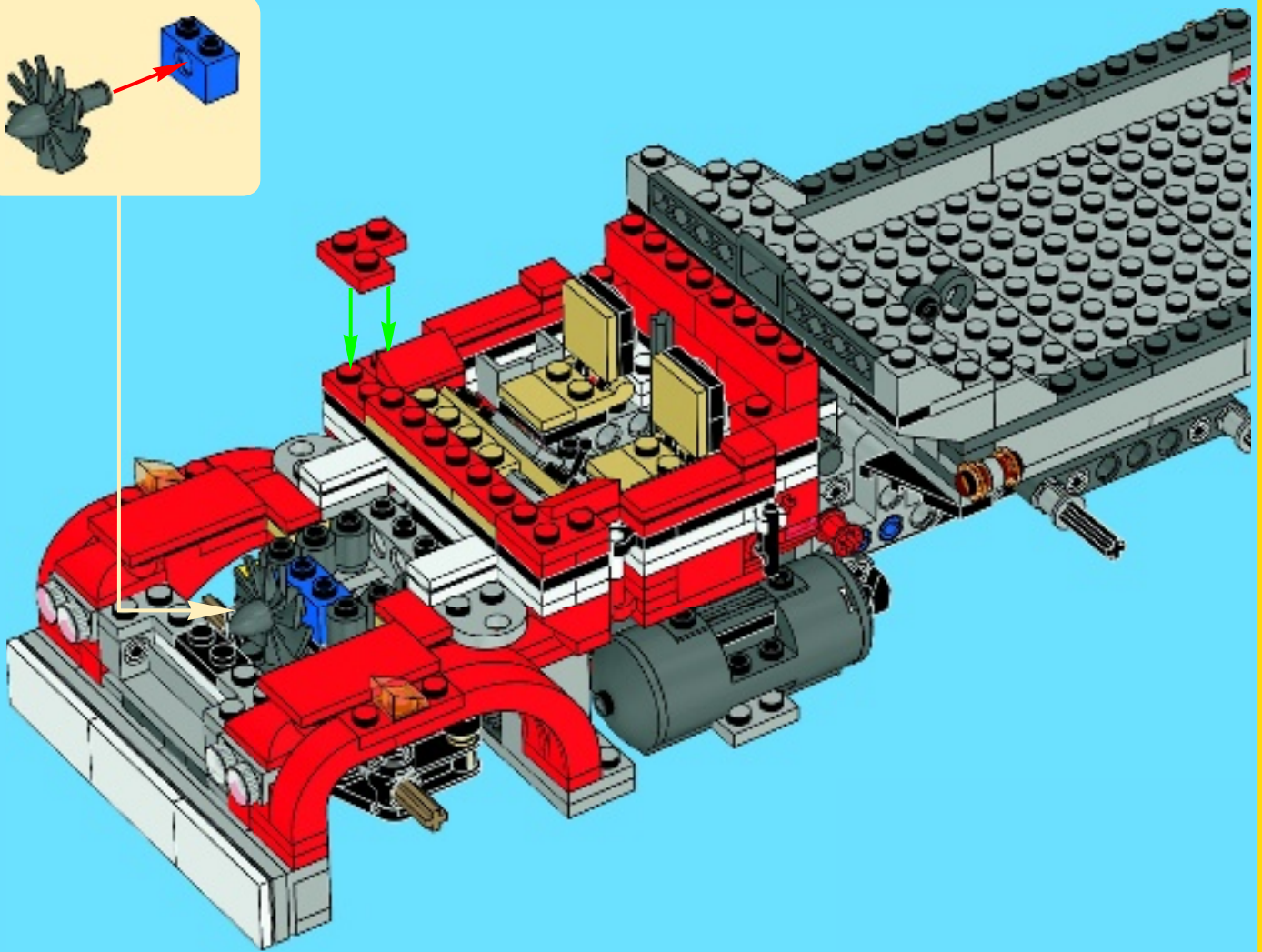
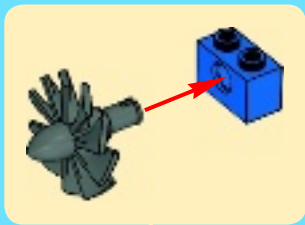



1x



1x



2x



1x

63

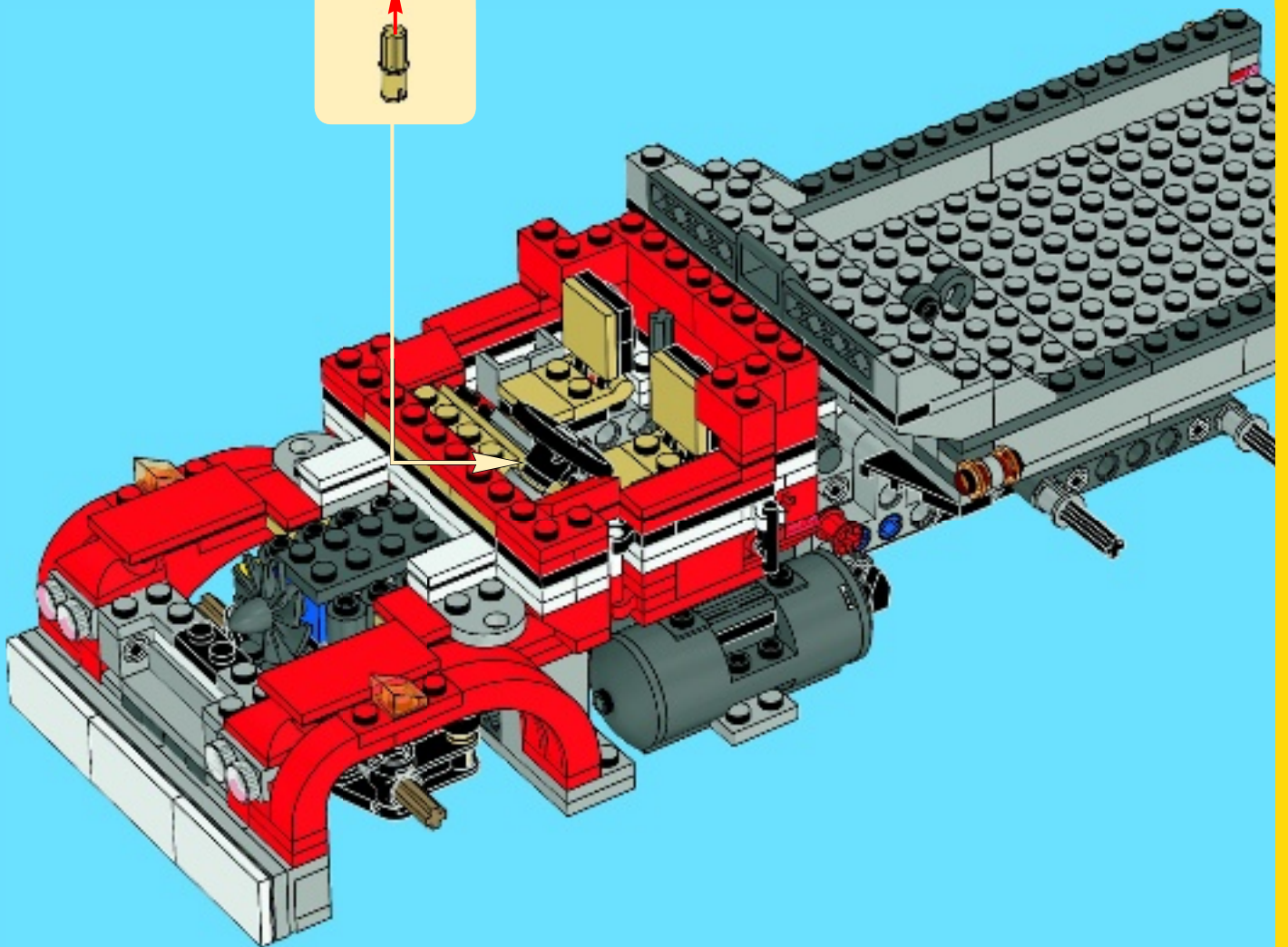
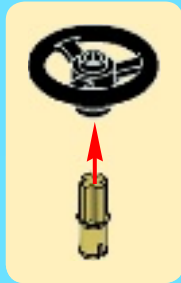

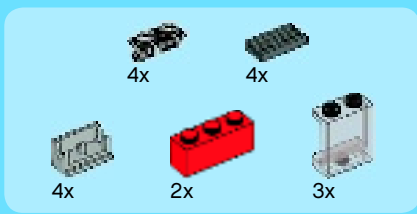

64

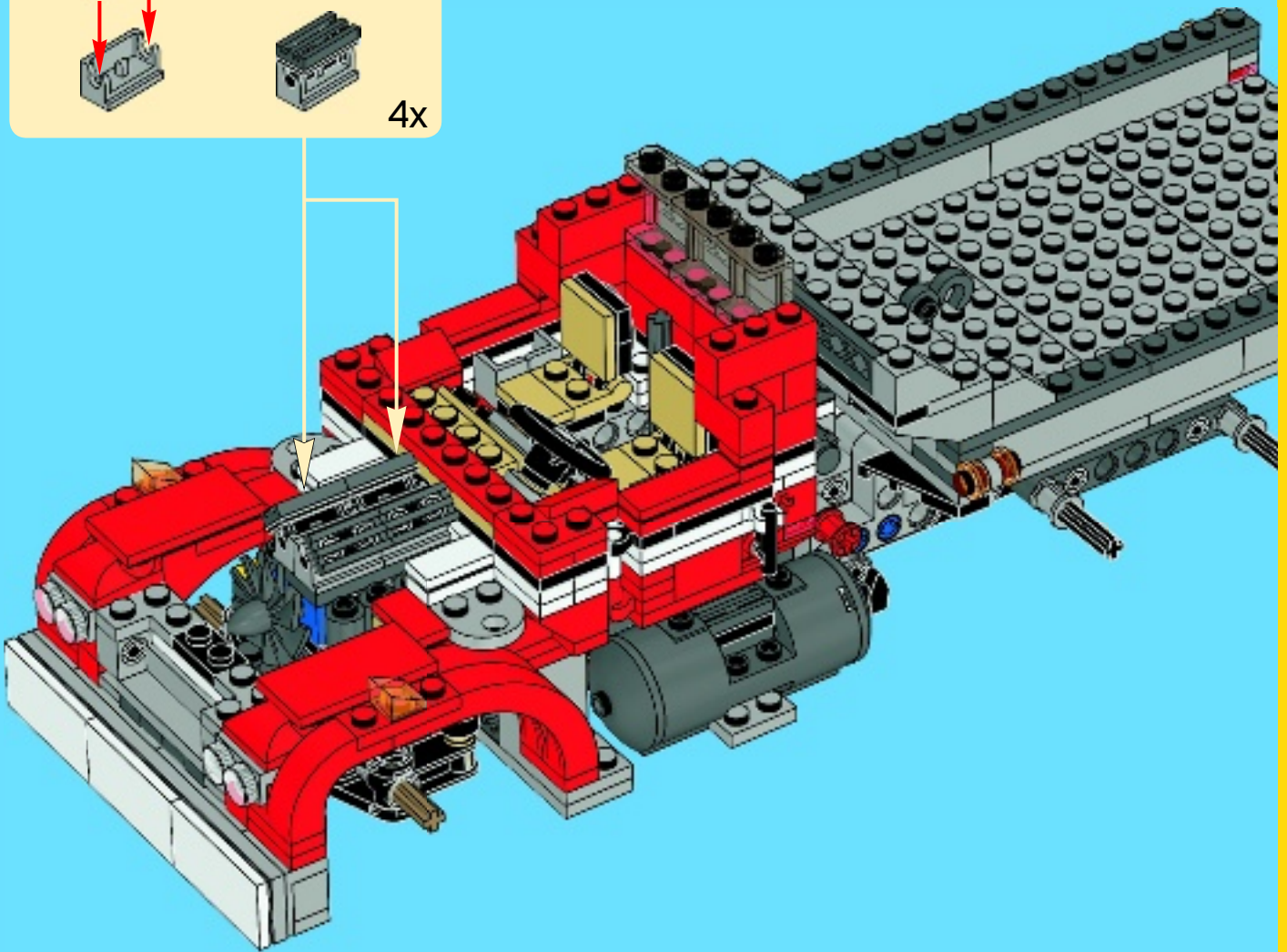
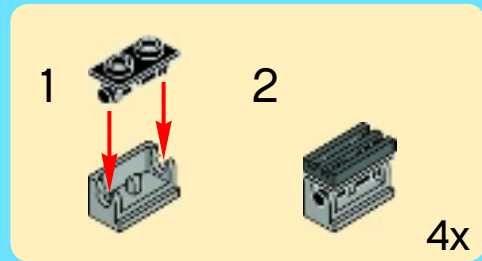



2x



1x



2x

65

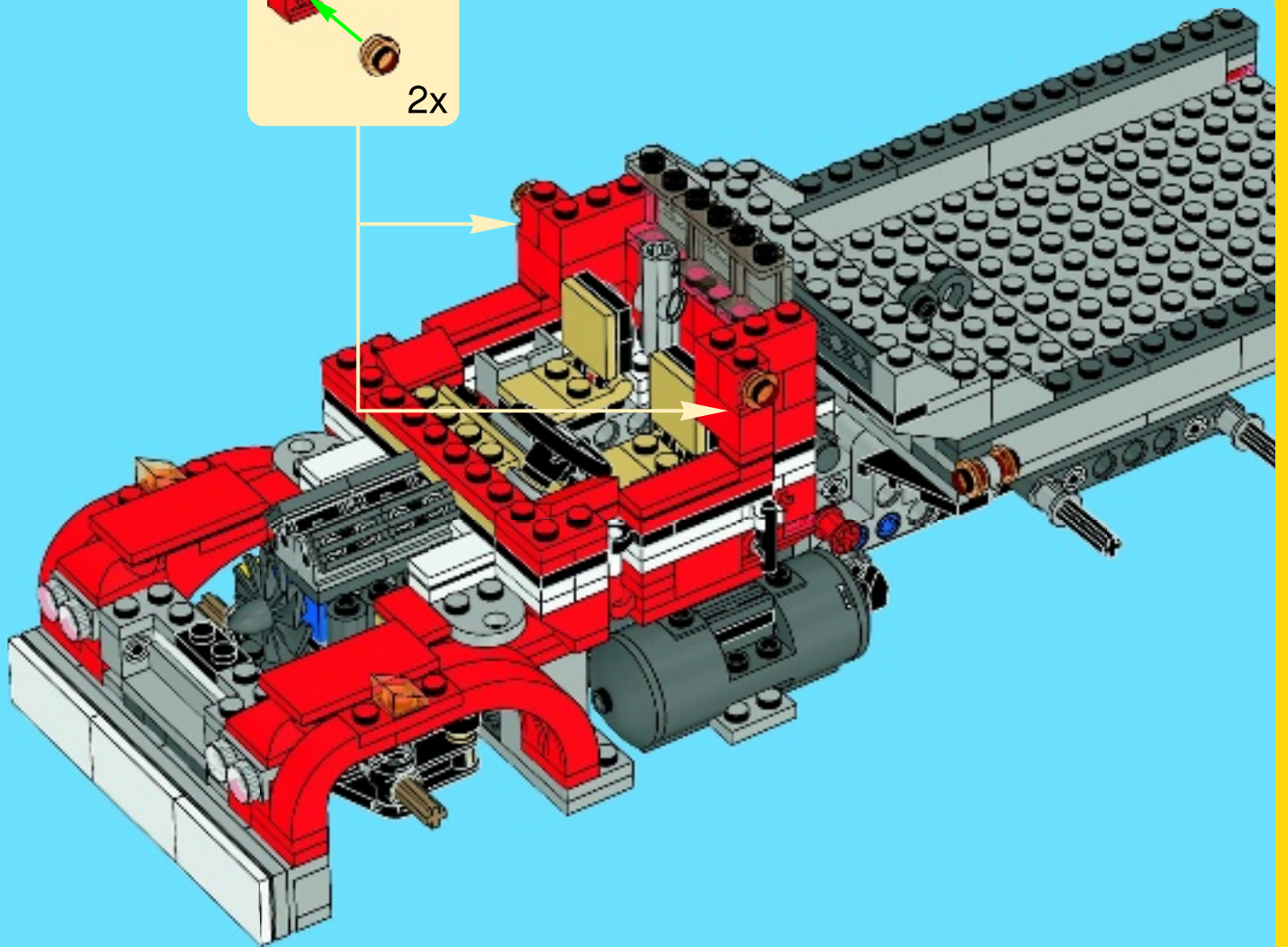
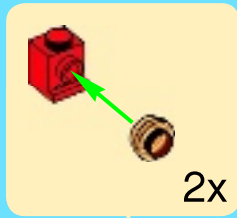



8x



2x



2x

4



4

1:1

66

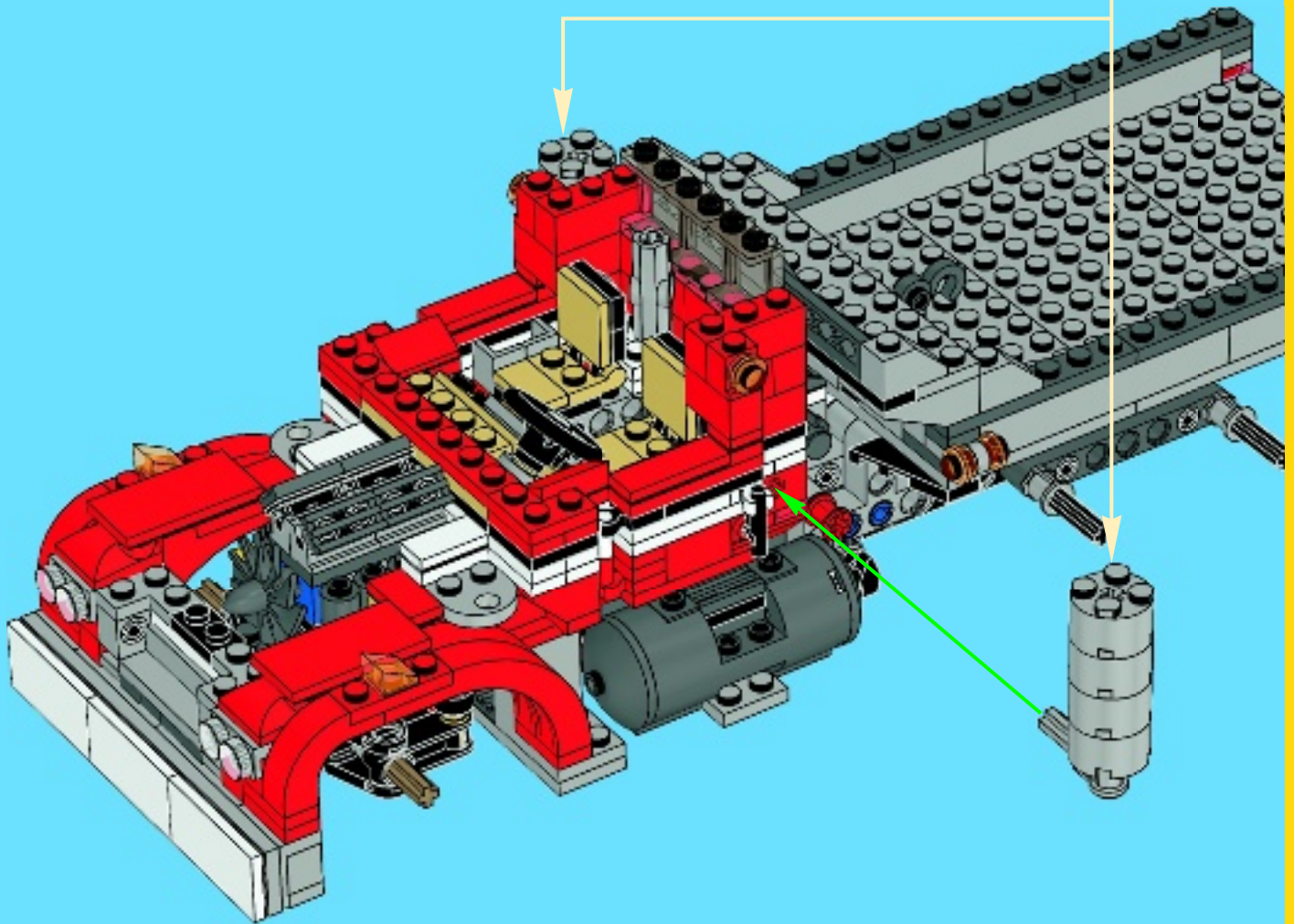
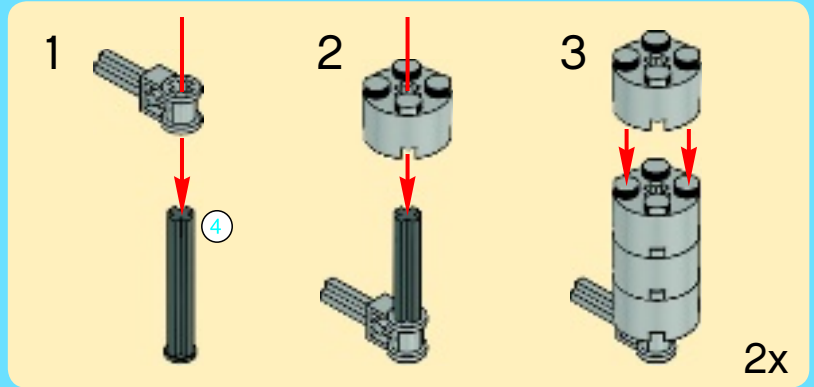

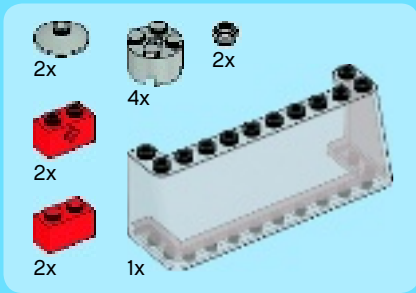

67

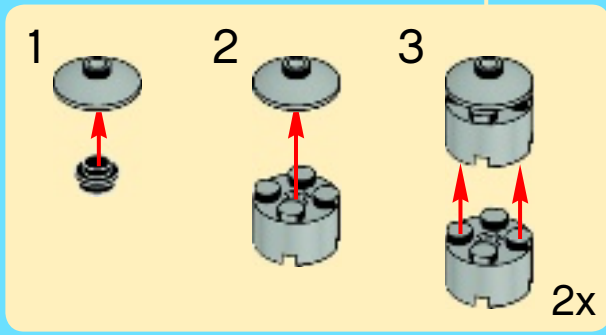
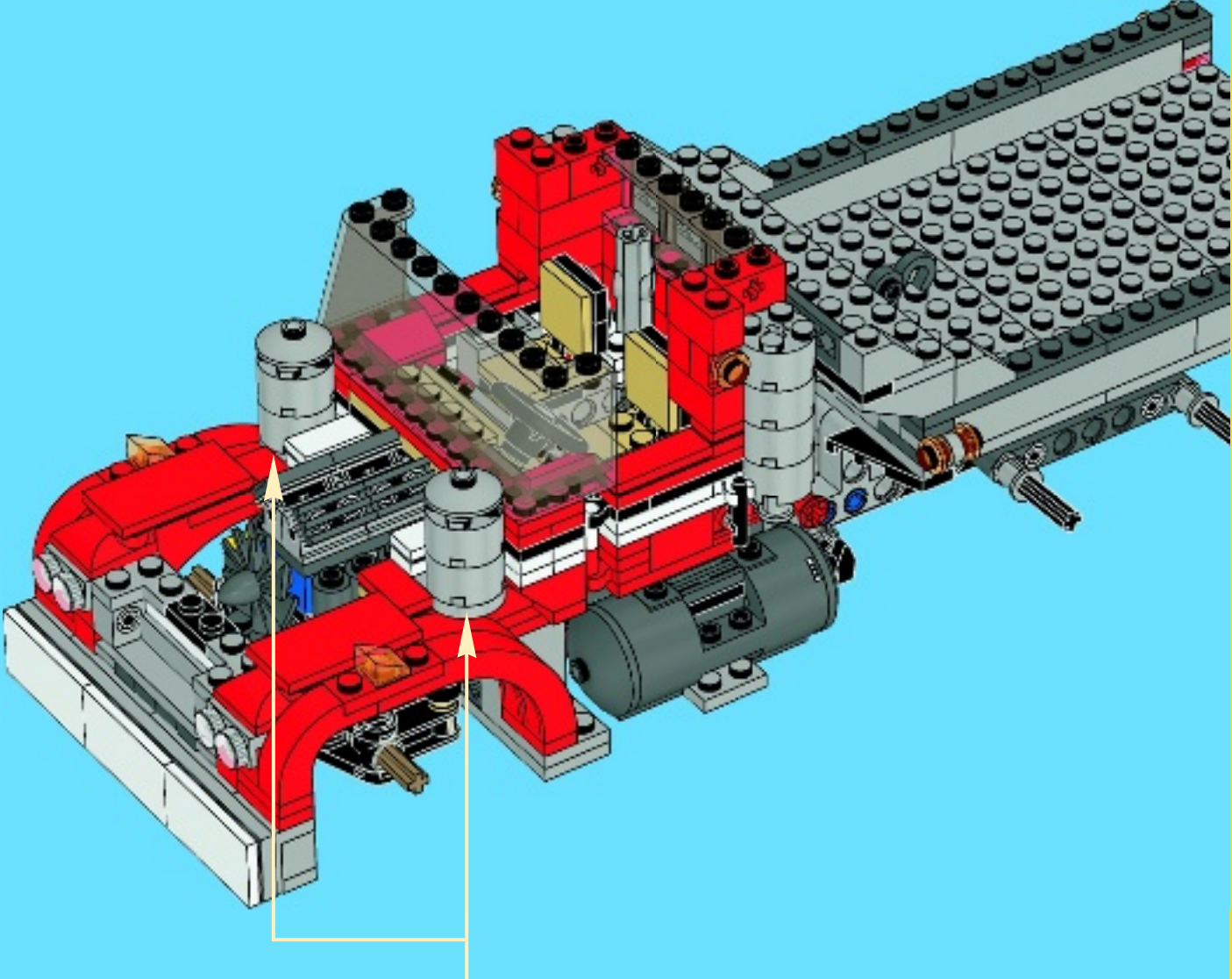

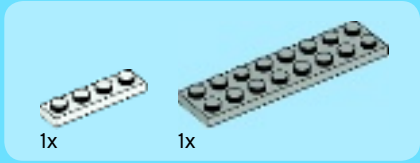

1

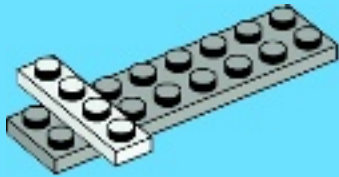

2

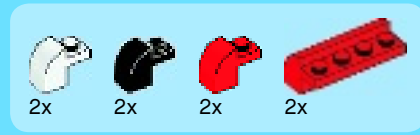

3

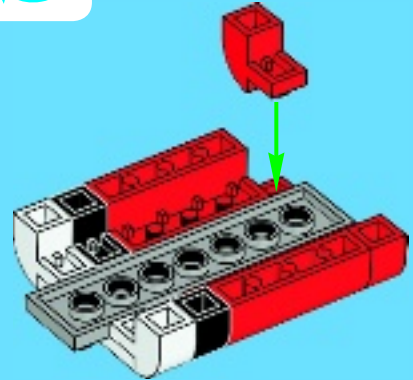

4

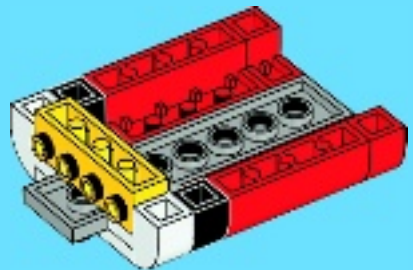



2x



2x

5

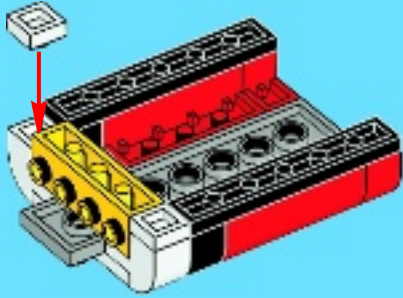

2x



2x

7

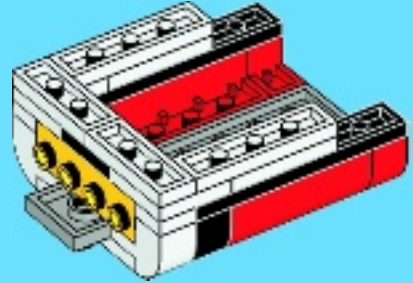

2x



1x



2x

6



2x



1x

8

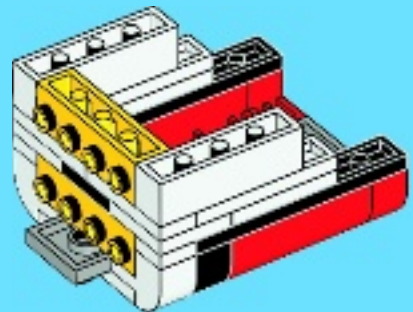

9

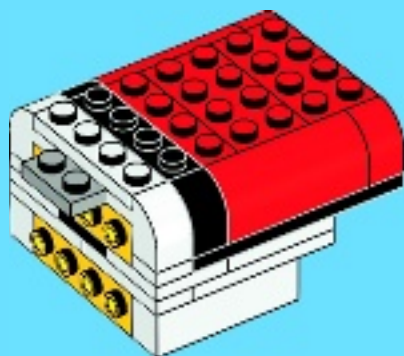

68

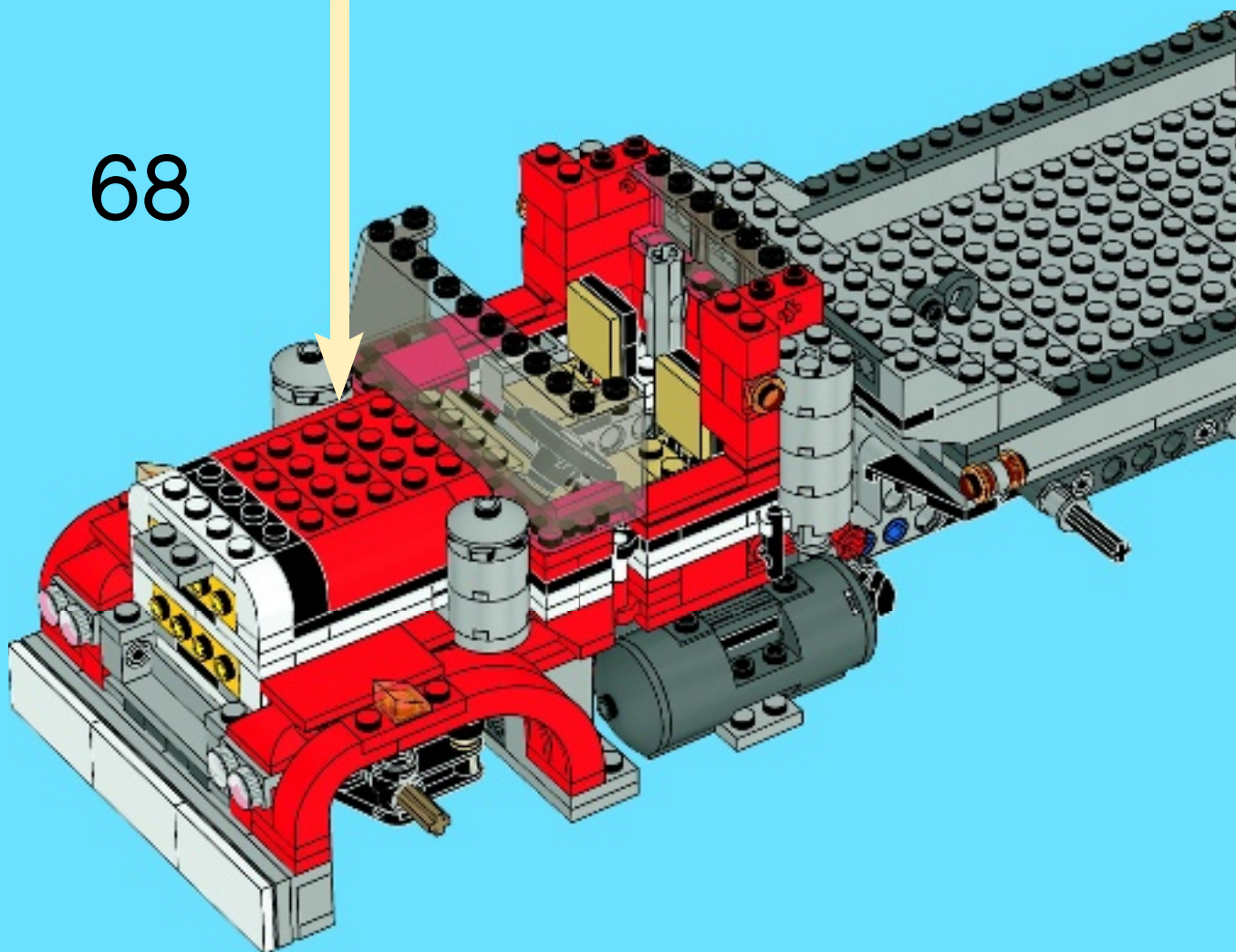



1x



8x

69

1



2

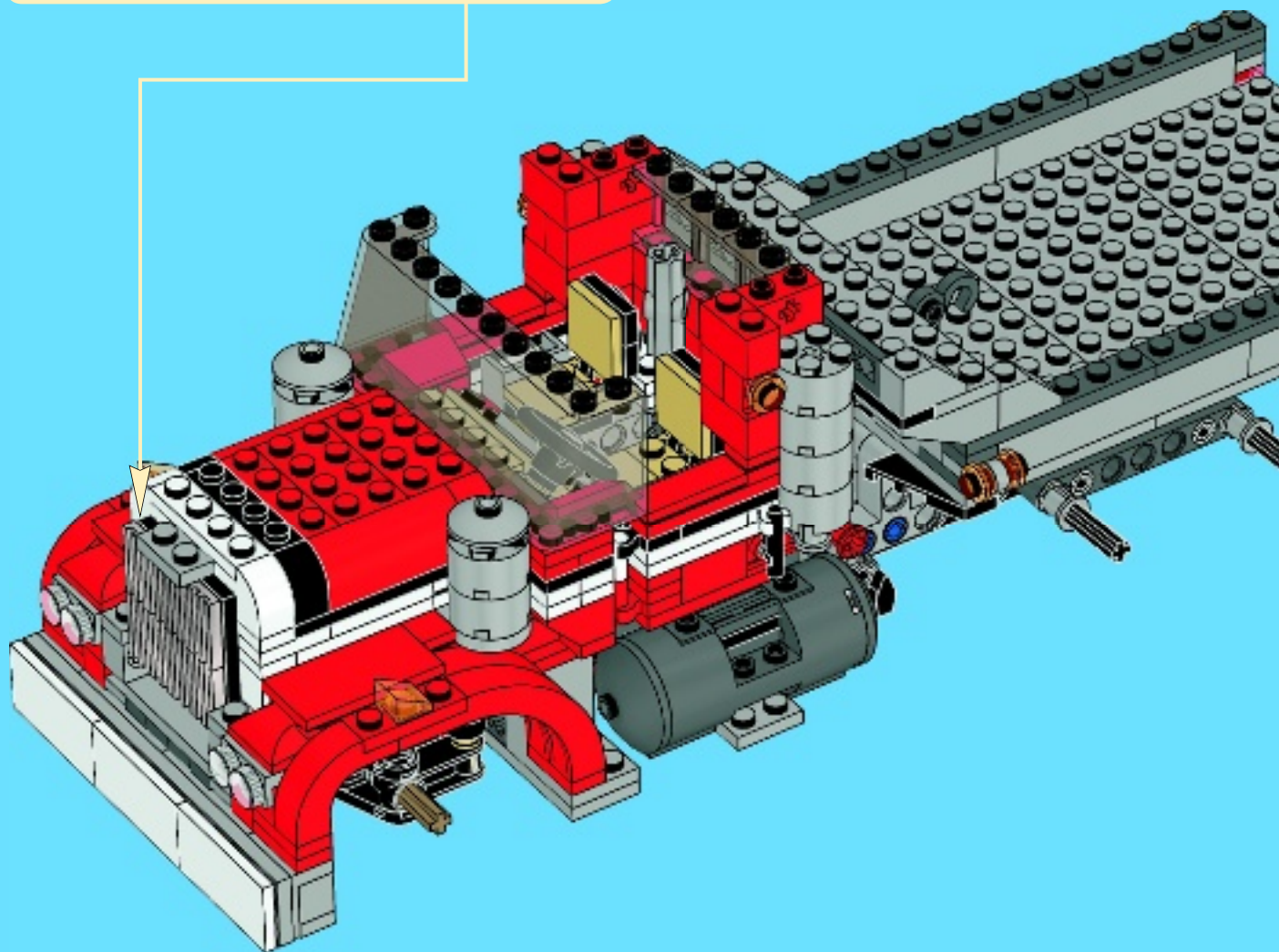
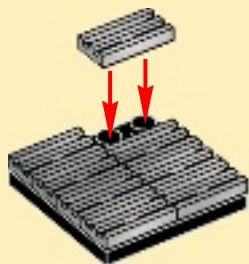



4x



2x

70

1



2

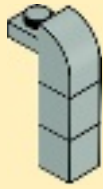

2x

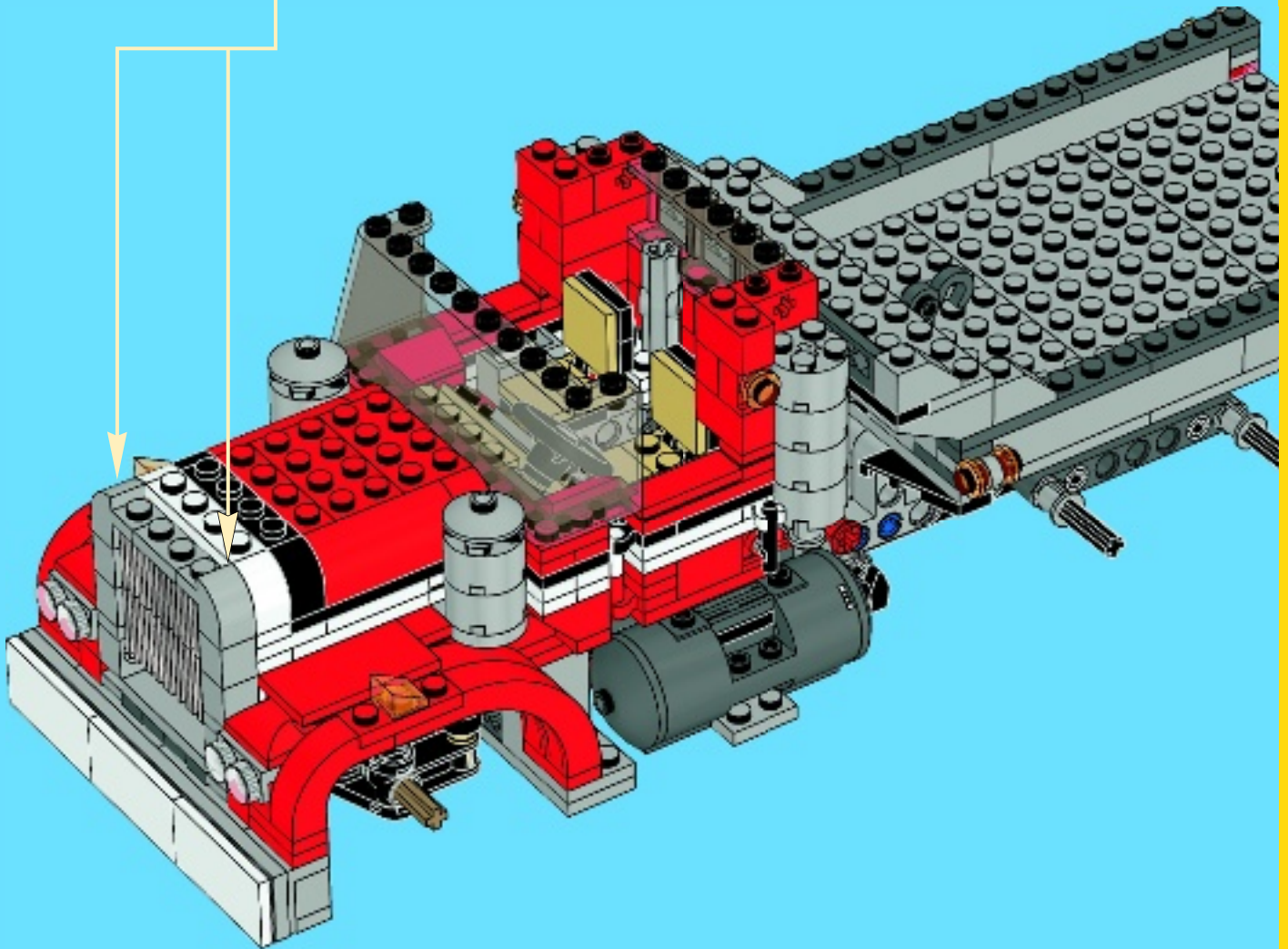



71

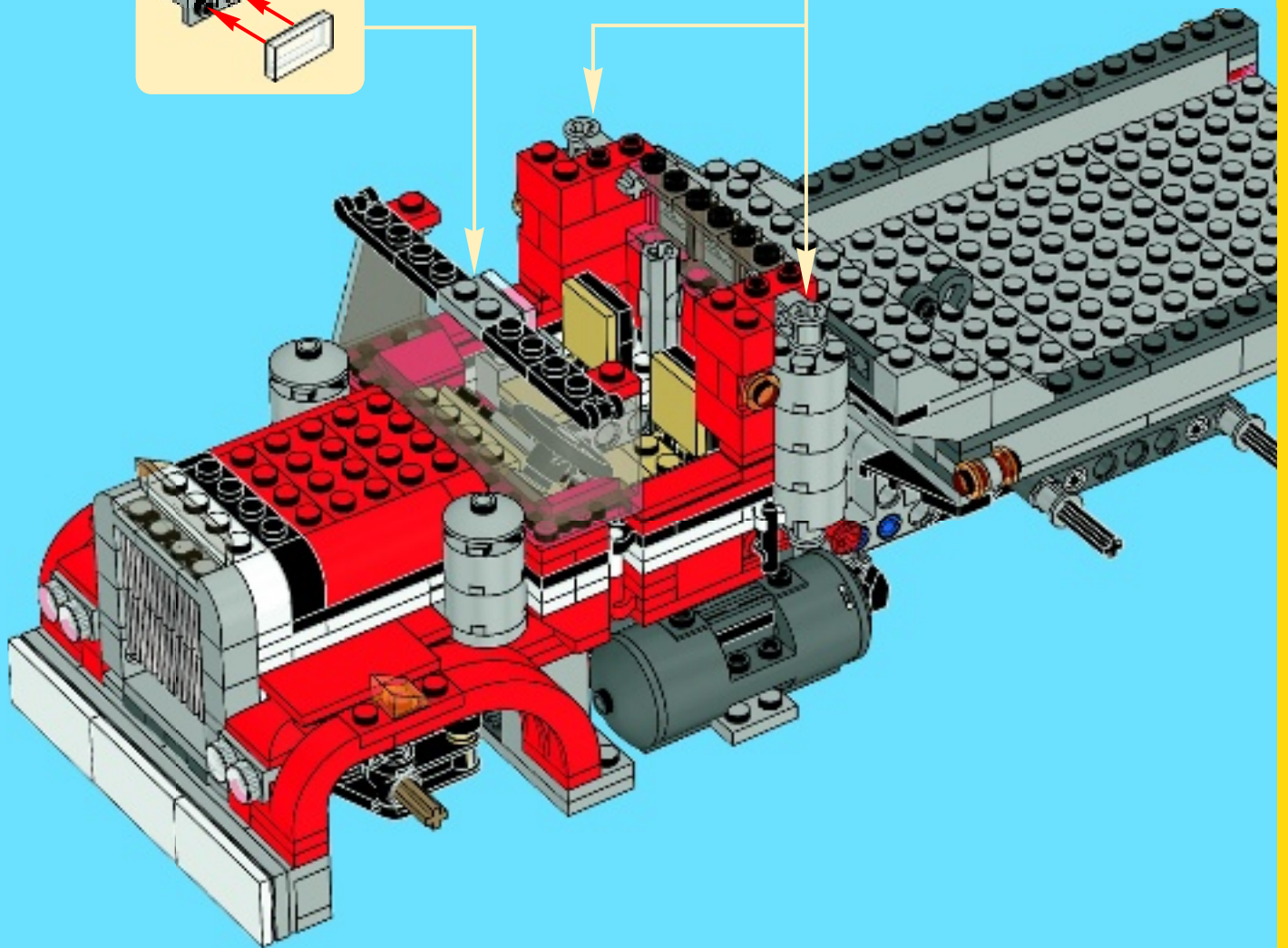
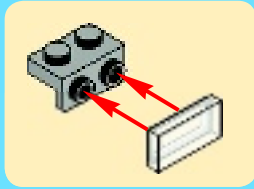

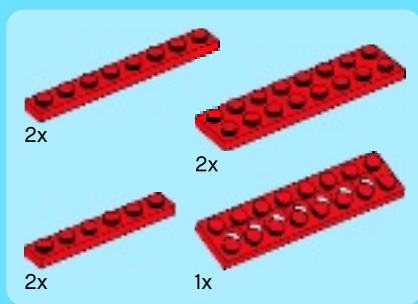

72

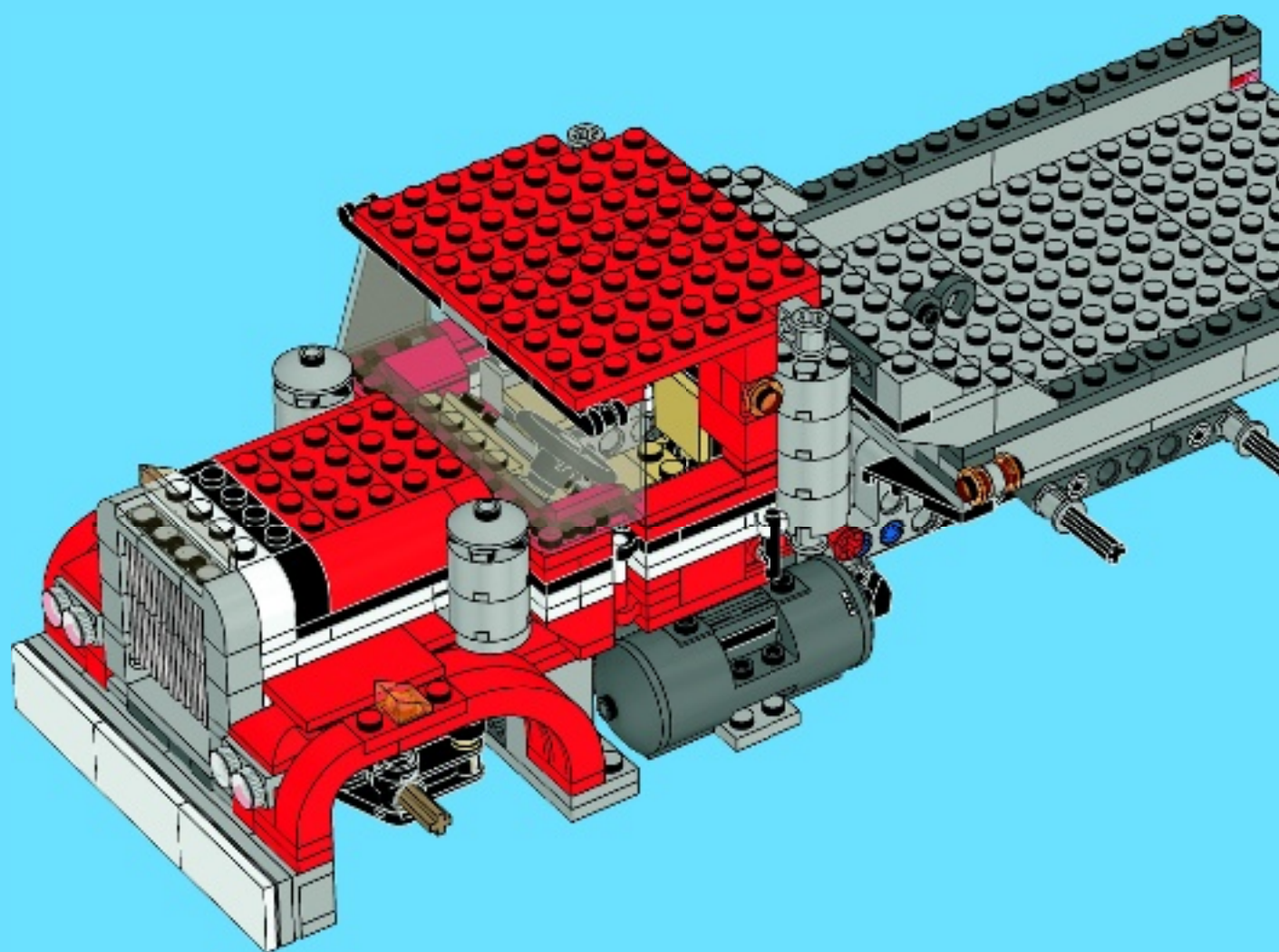



1x



2x



1x

73

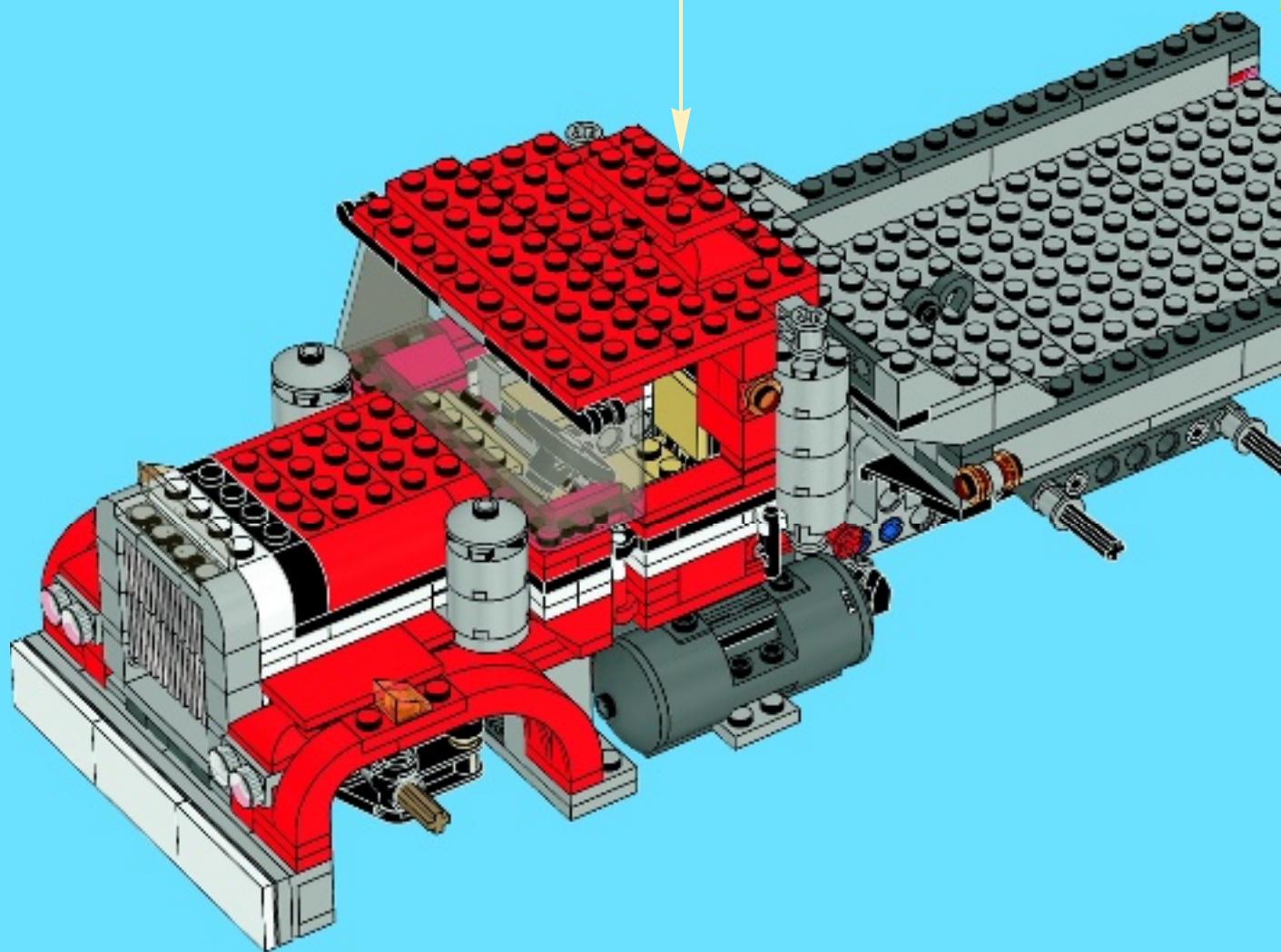
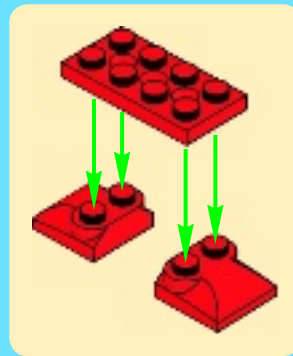



74

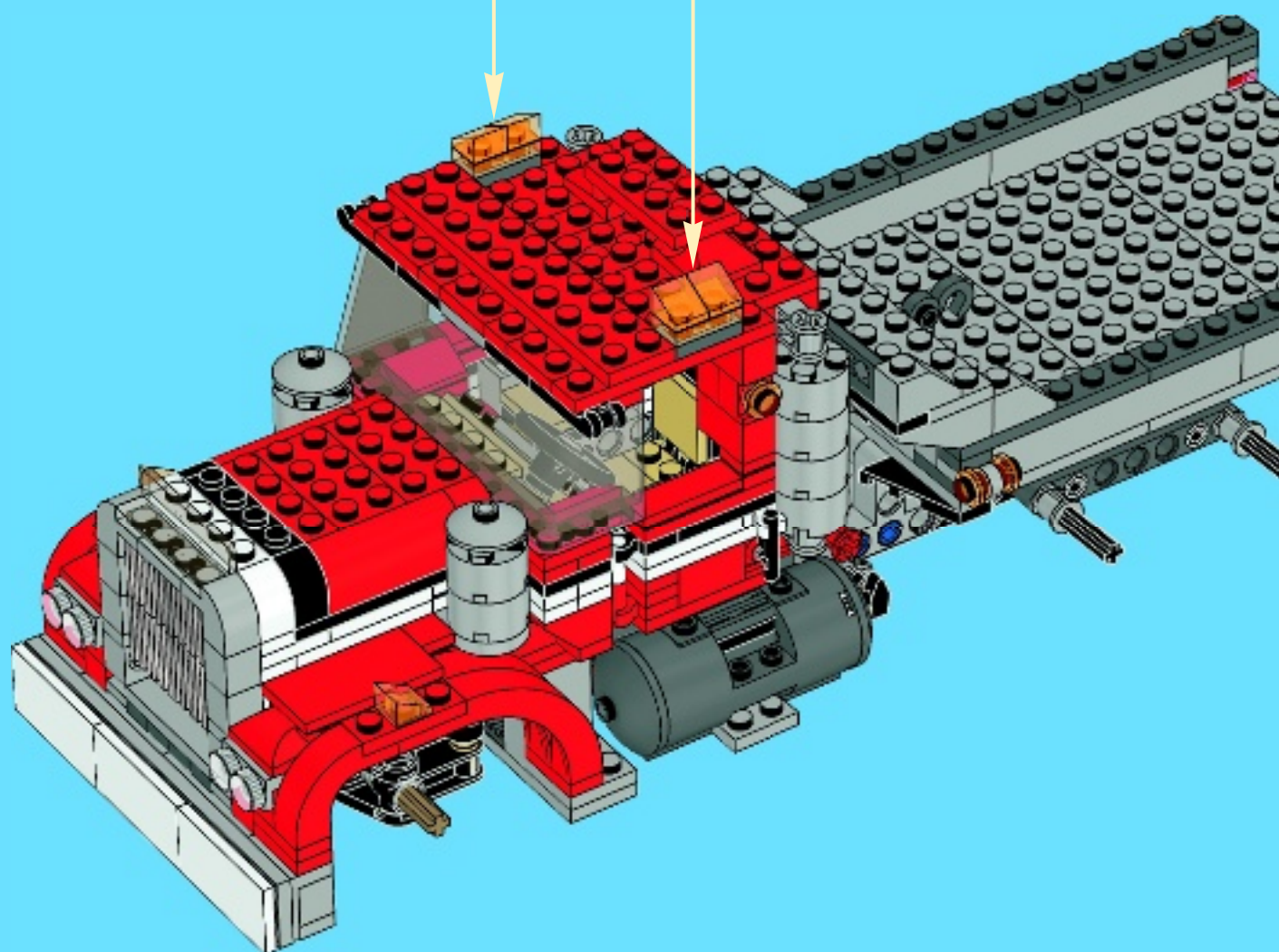
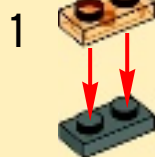



2x



75

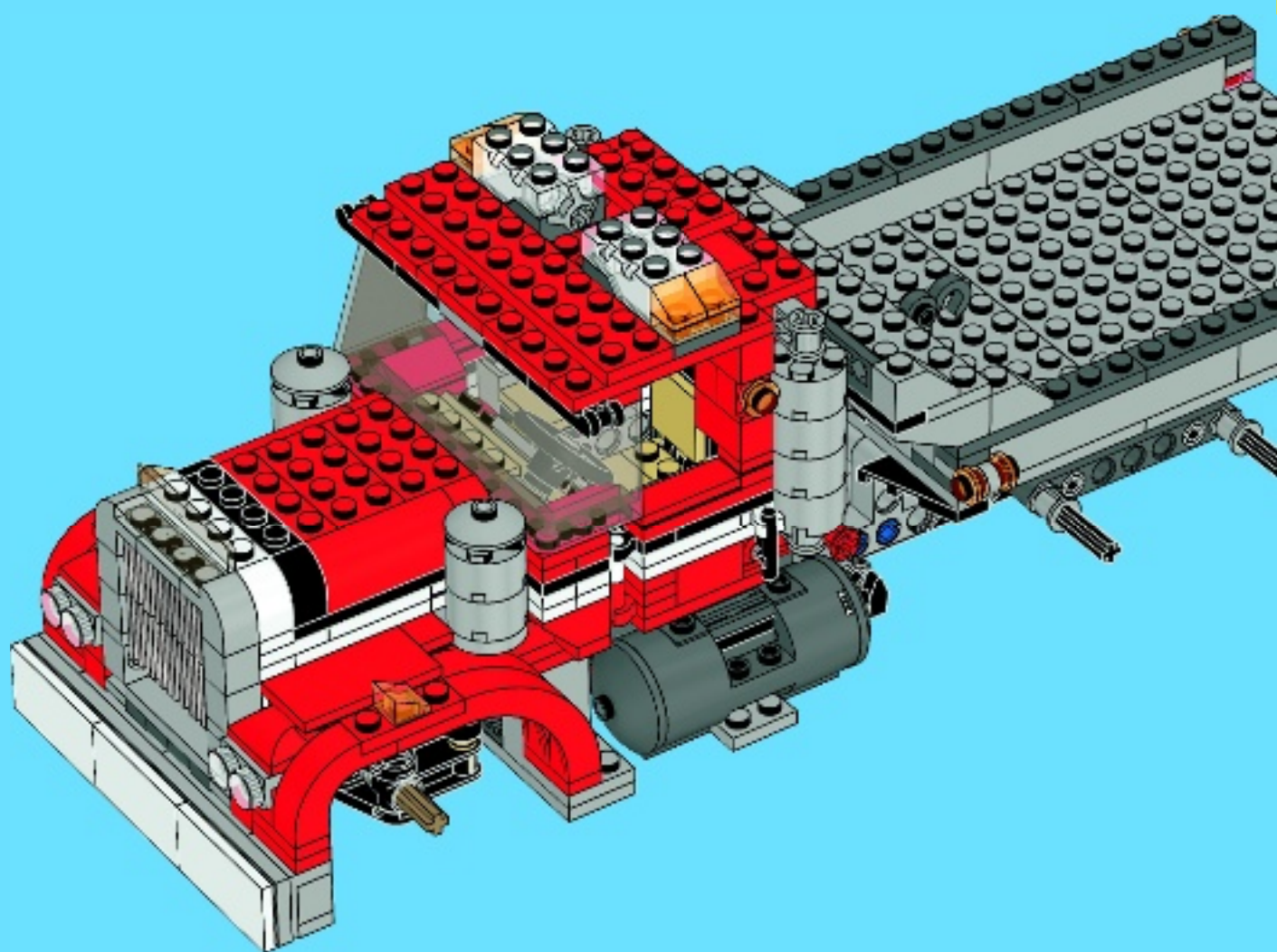

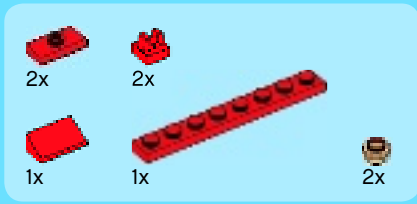

76

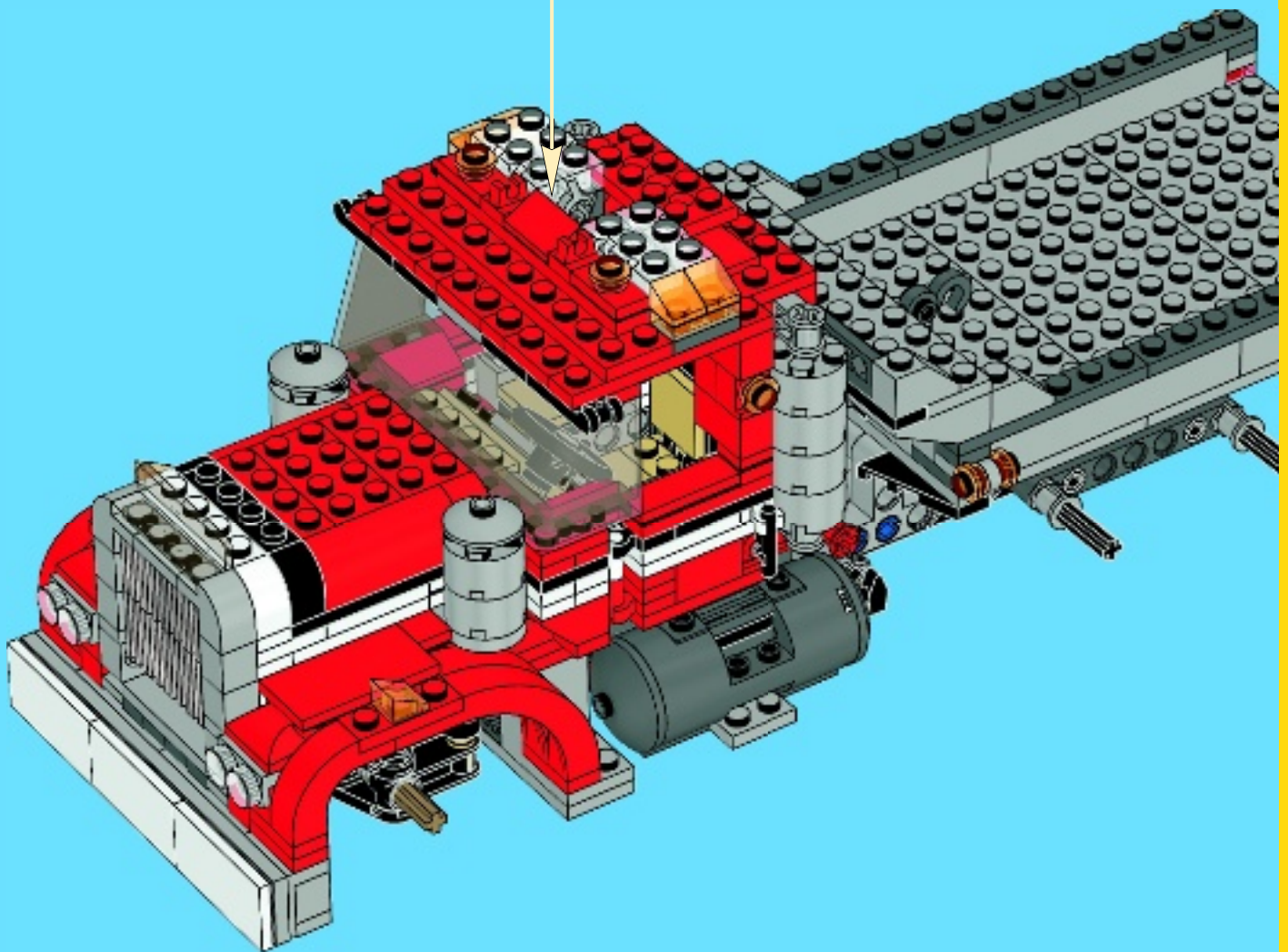
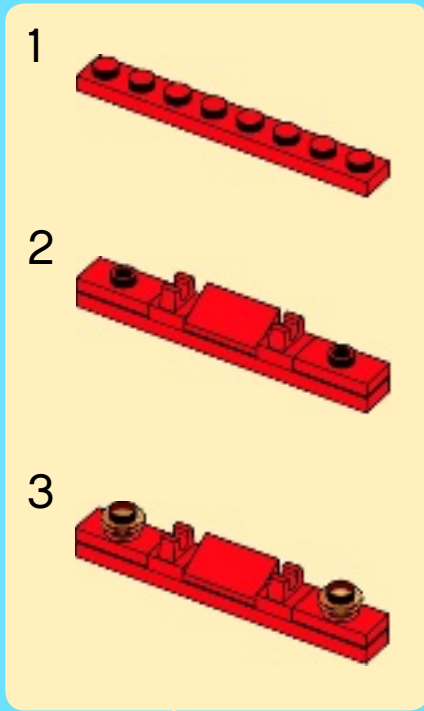



1x



1x



1x



2x



1x

77

1

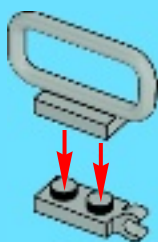

1



2

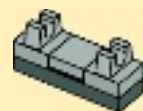

2

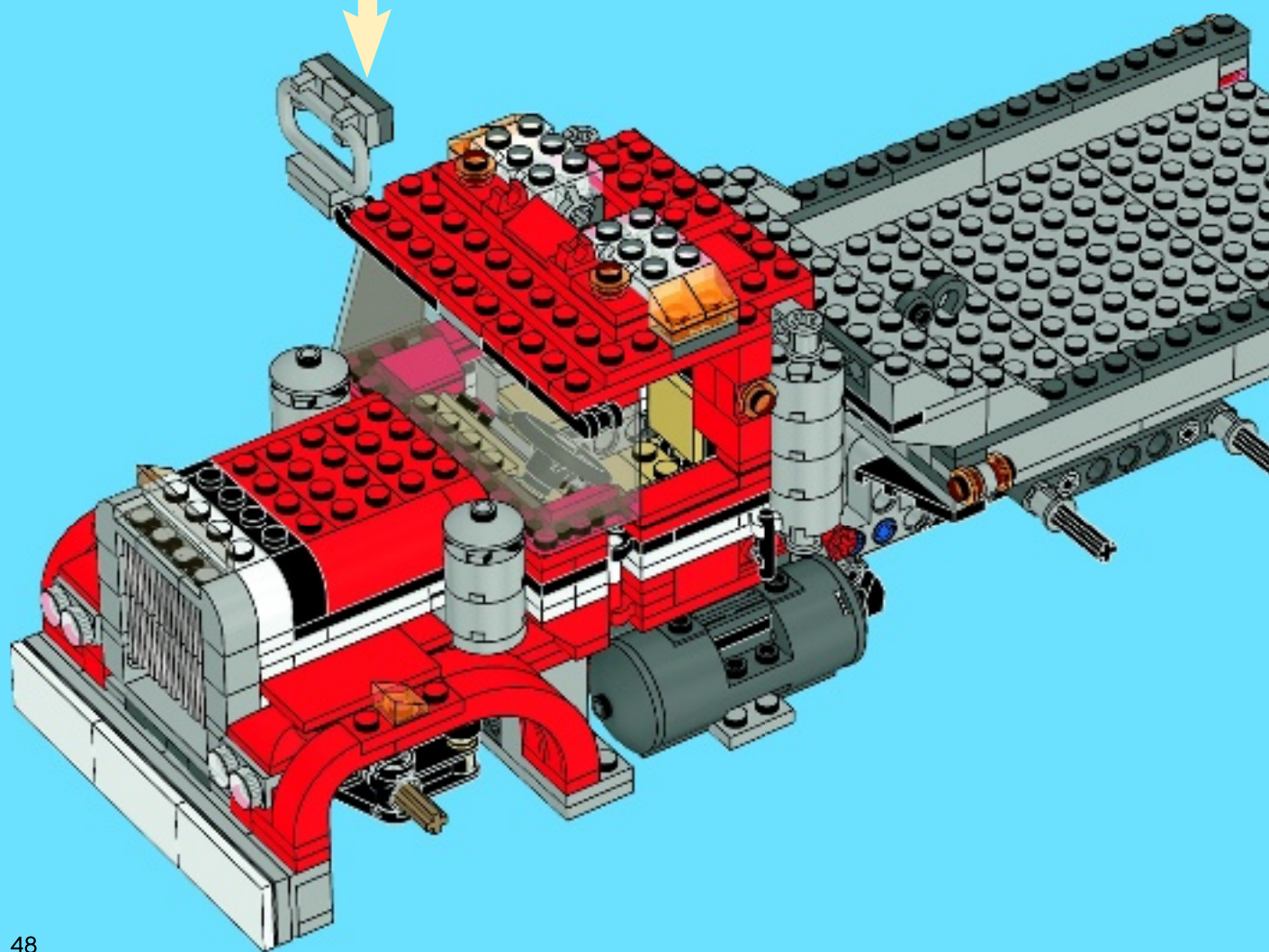
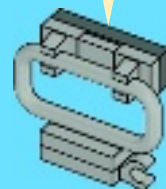

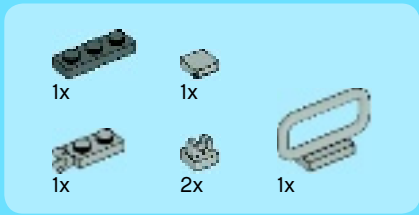

78

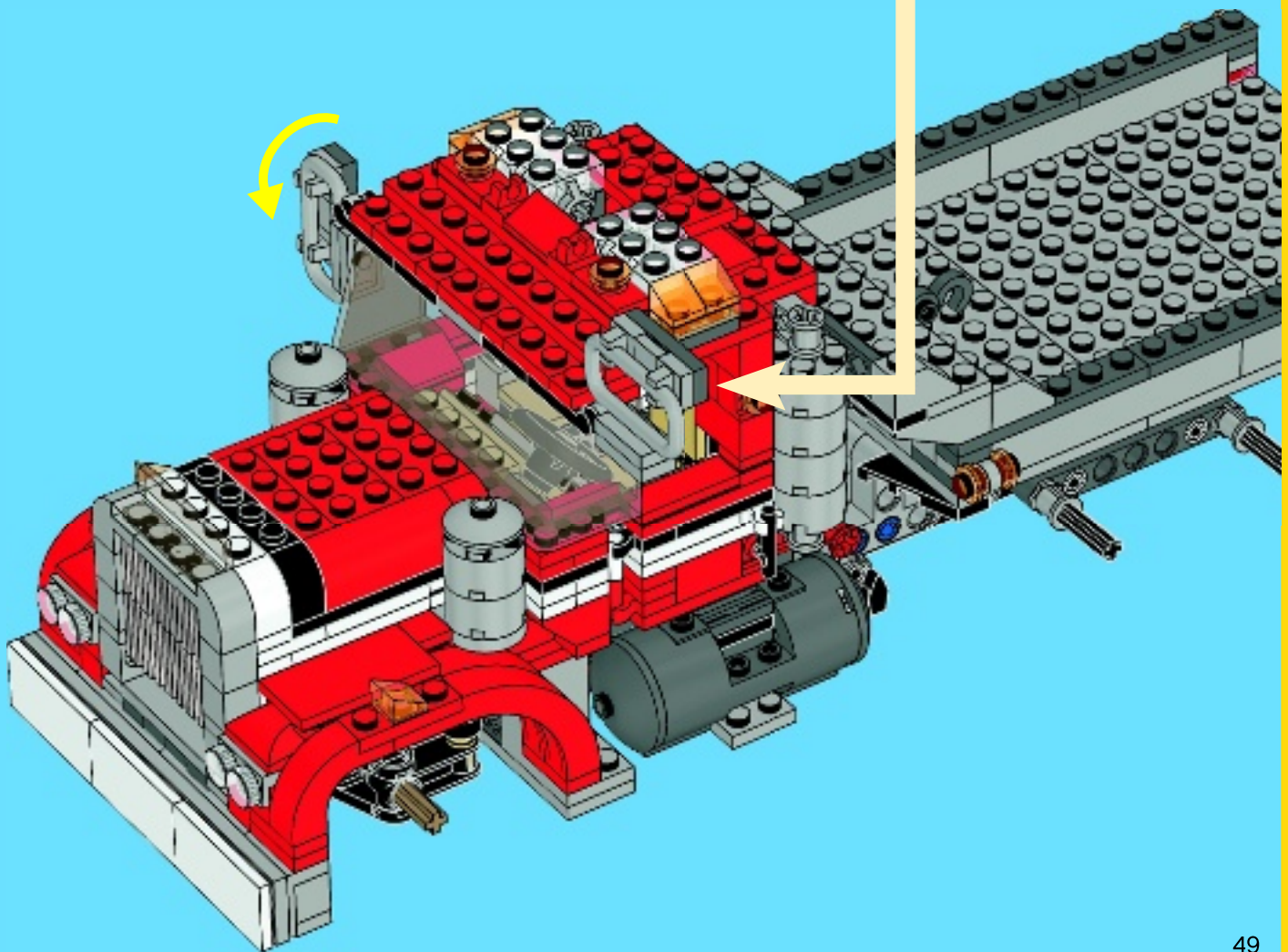
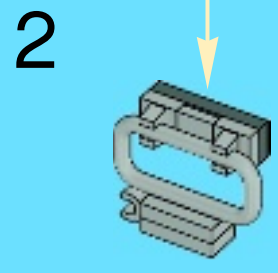
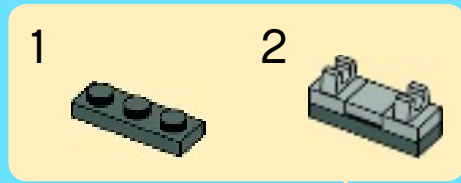
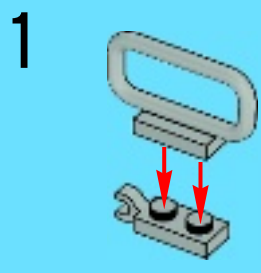



79

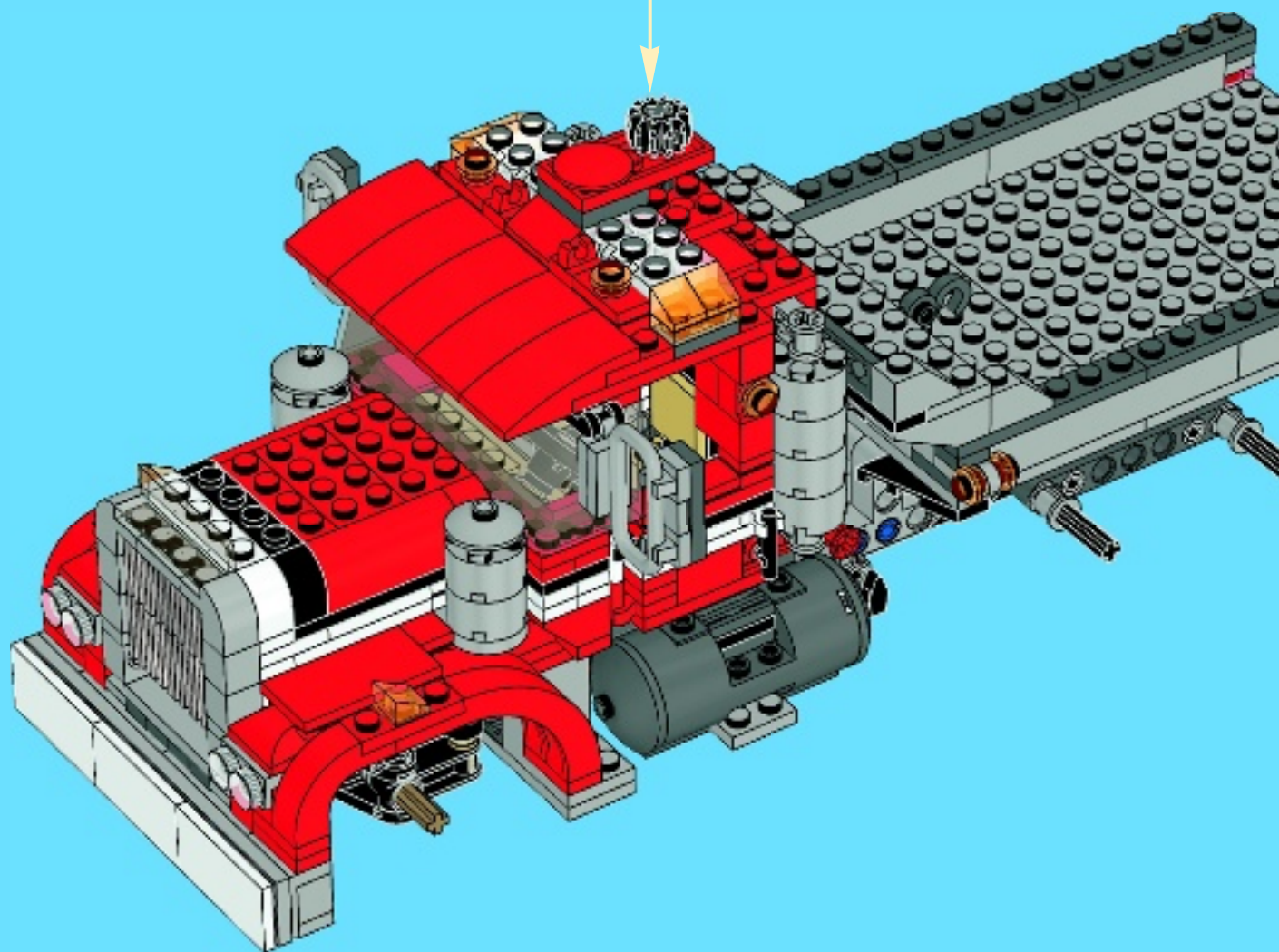
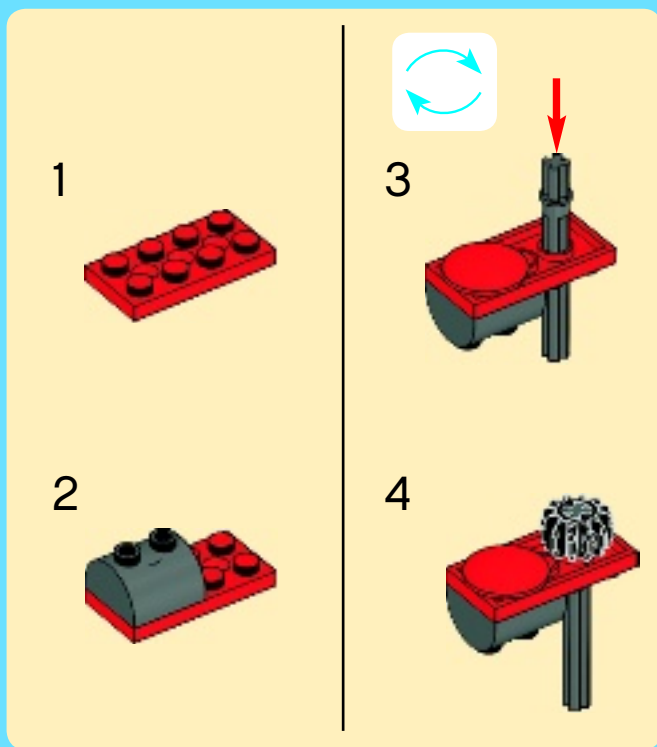

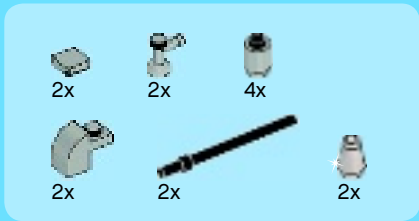

80

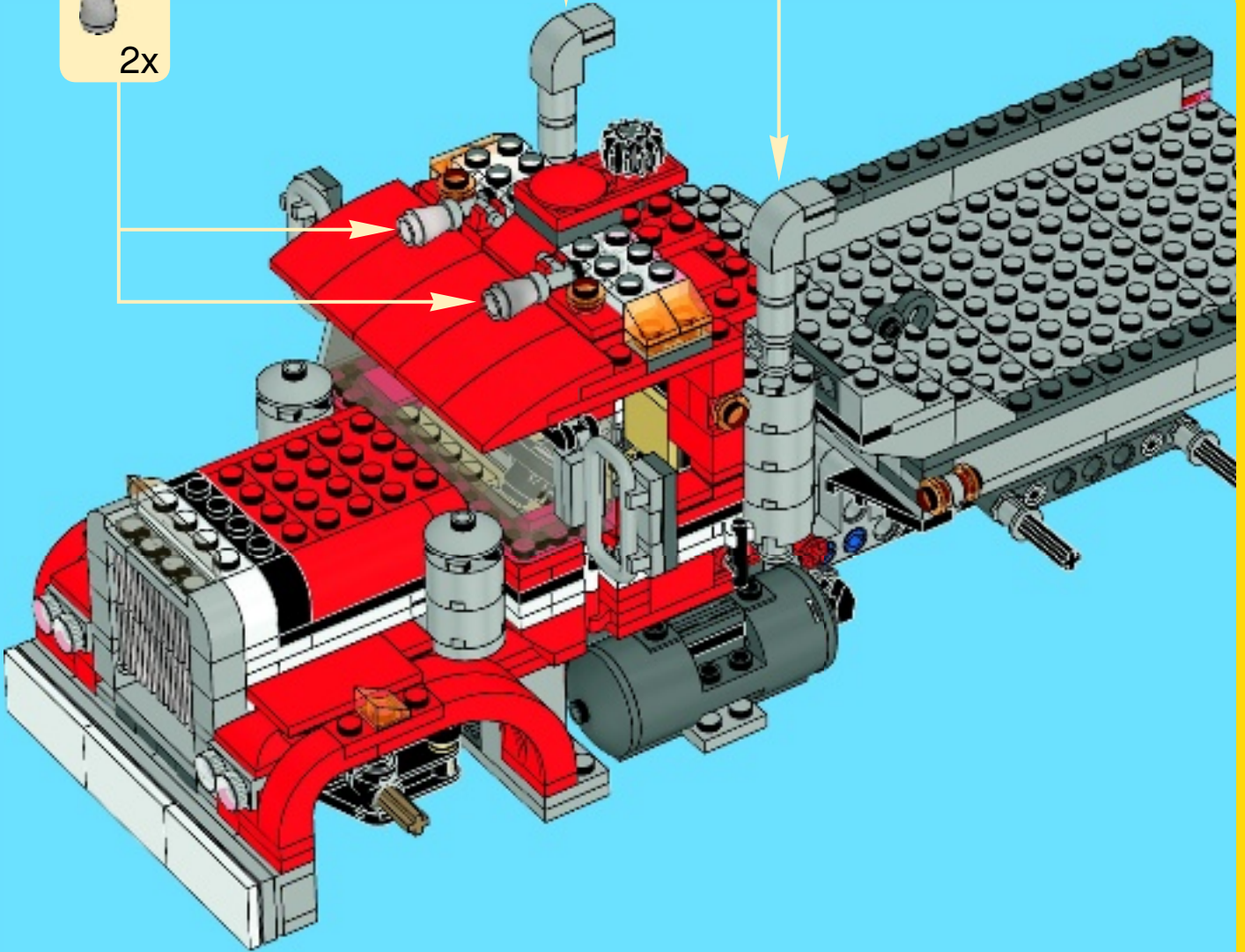
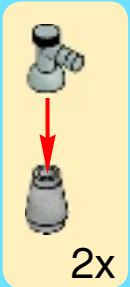
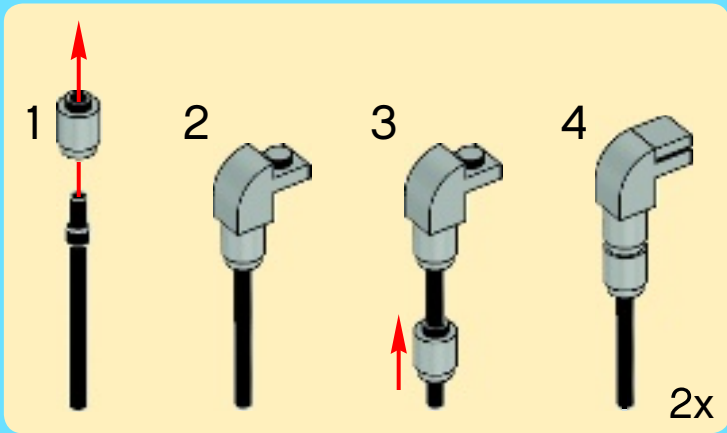



81

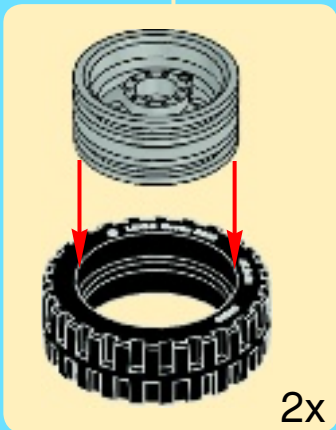
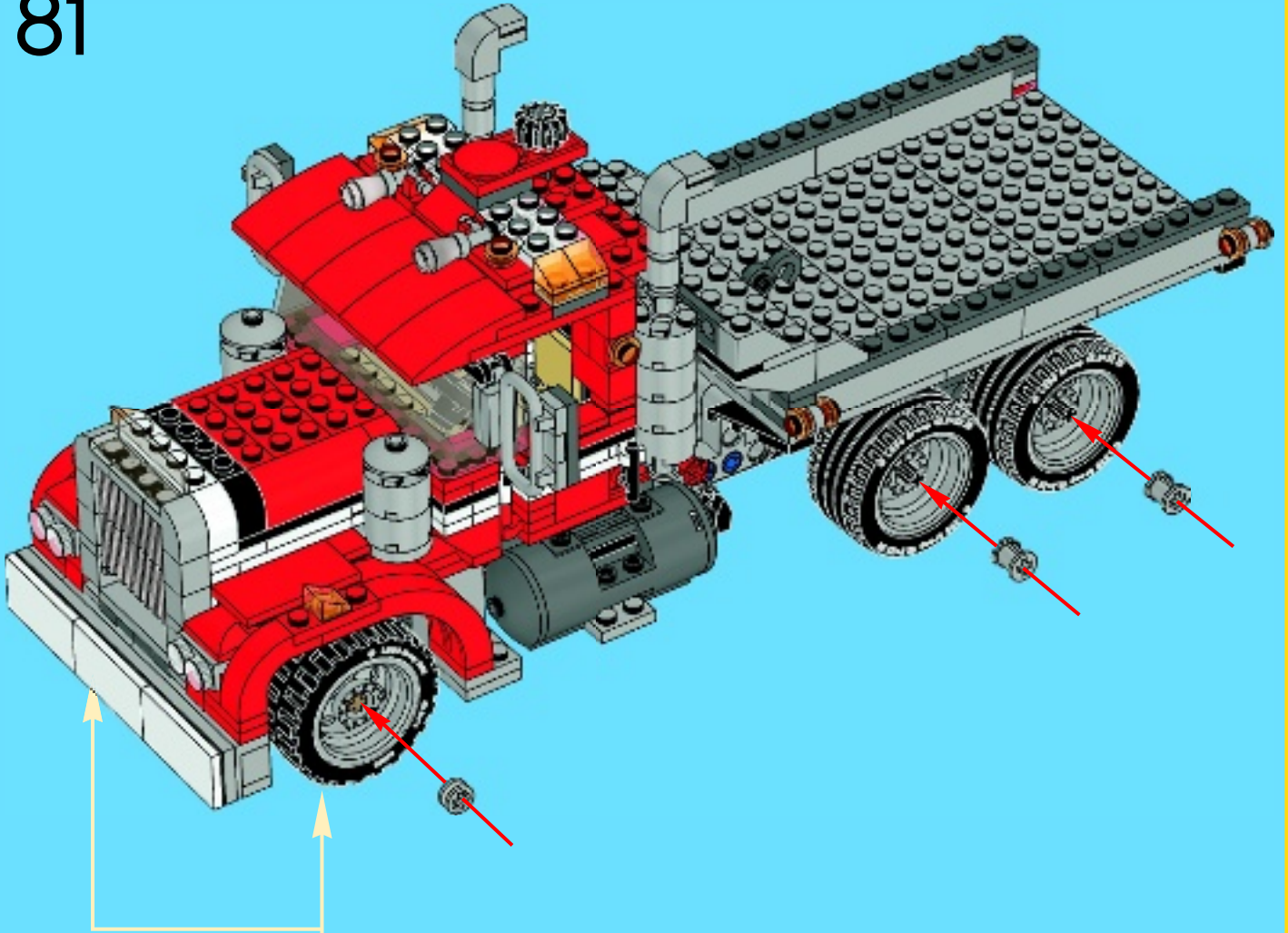

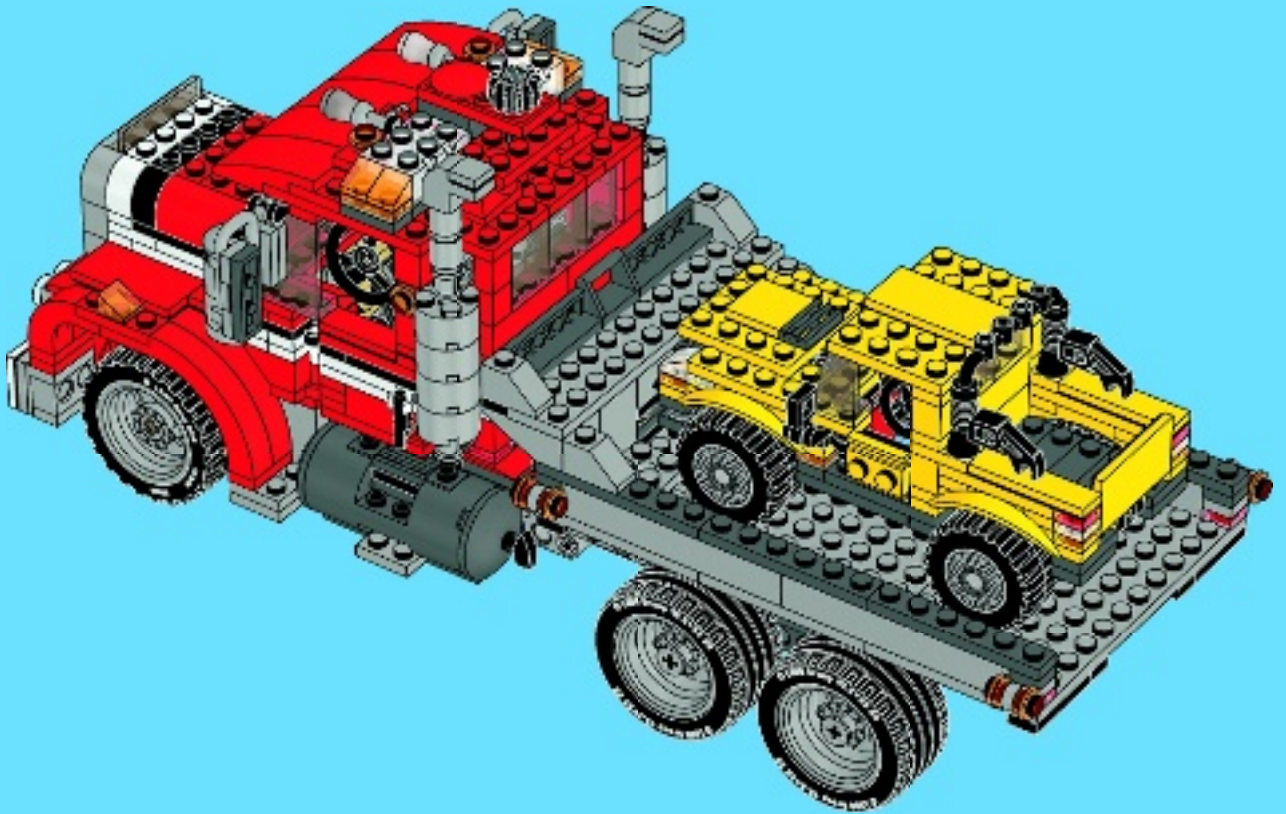
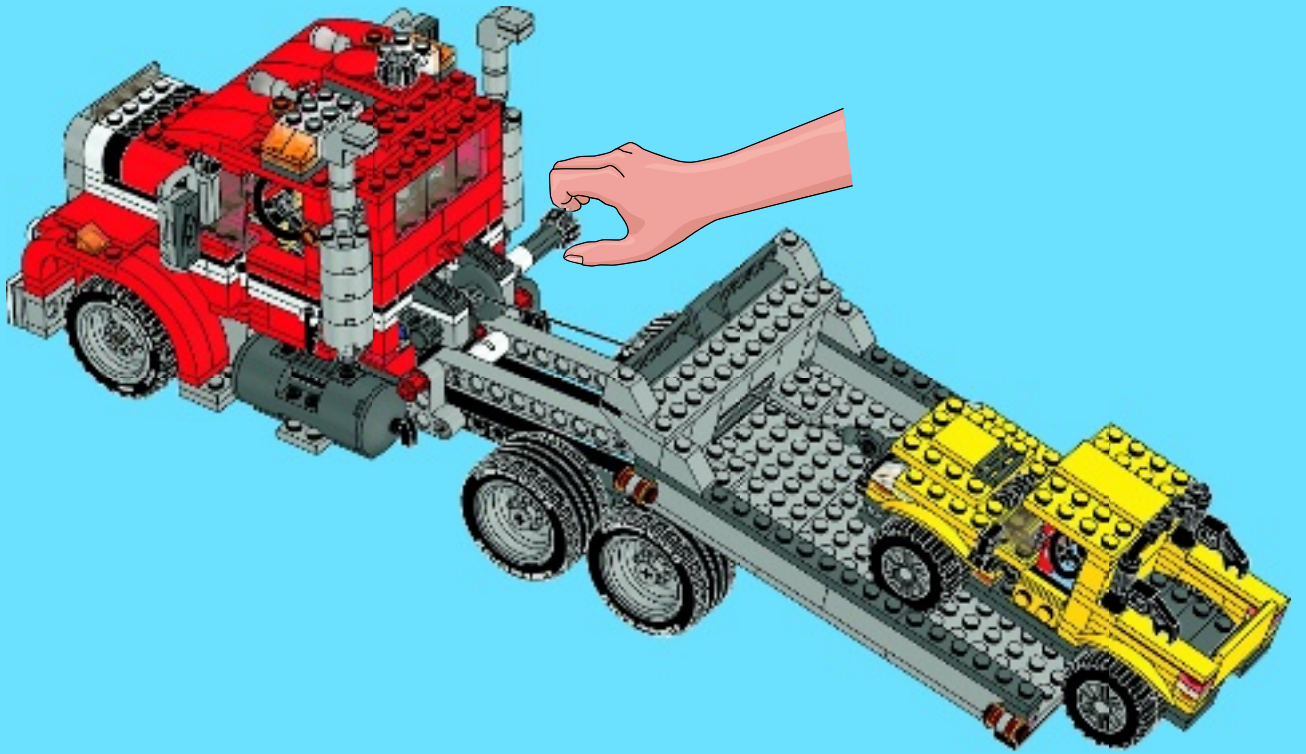

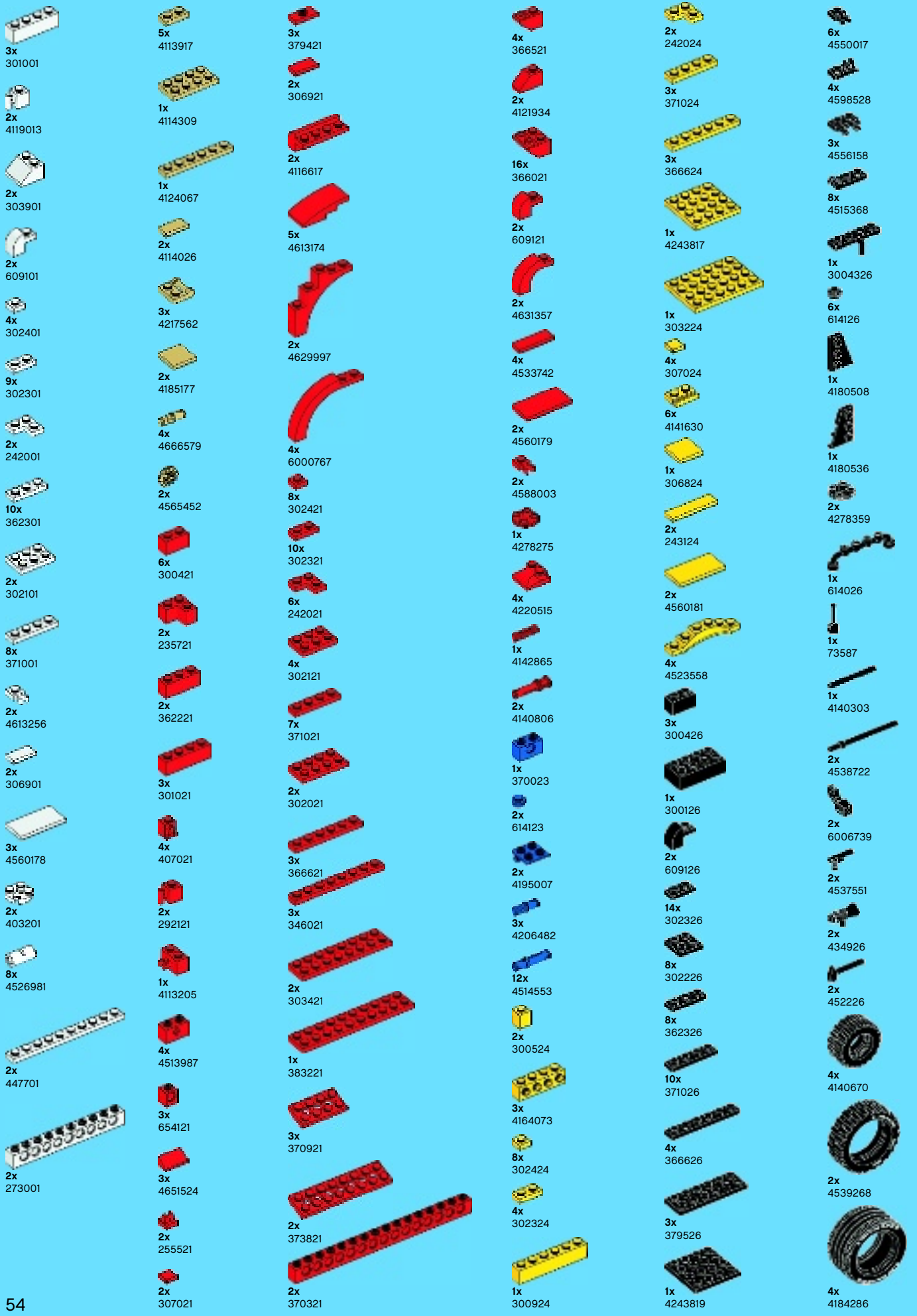

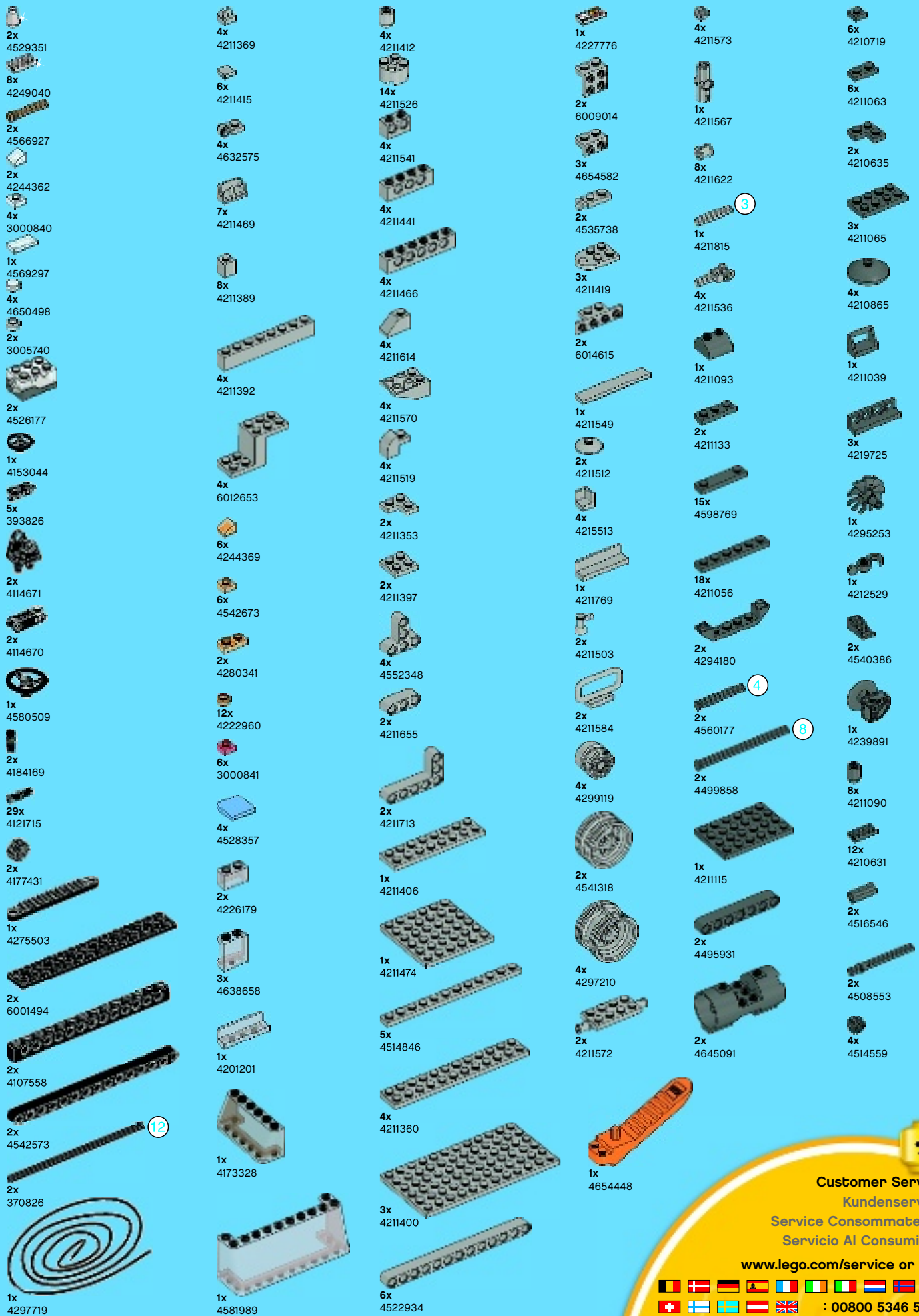

Customer Service
Kundenservice
Service Consommateurs
Servicio Al Consumidor

www.lego.com/service or dial

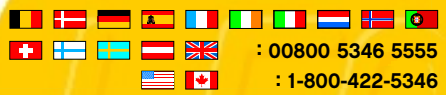

: 00800 5346 5555
: 1-800-422-5346



WIN!

Go to www.LEGOsurvey.com/product to fill out a survey for a chance to win a cool LEGO® Product. No purchase necessary. Open to all residents where not prohibited.

 www.LEGO.com



www.LEGOsurvey.com/product

GEWINNE!

Nimm an der Umfrage auf www.LEGOsurvey.com/product teil und hab die Chance ein cooles LEGO® Produkt zu gewinnen! Die Teilnahme am Gewinnspiel führt zu keinerlei Kaufverpflichtungen. Teilnahme in allen nicht ausgeschlossenen Ländern möglich.

WIN!

Ga naar www.LEGOsurvey.com/product, vul een enquêteformulier in en maak kans op een cool LEGO® product. Geen aankoopverplichting. Iedereen mag deelnemen, uitgezonderd ingezetenden van landen waar een enquêteverbod geldt.

GAGNE!

Visite www.LEGOsurvey.com/product pour répondre à un questionnaire et avoir une chance de gagner un produit LEGO® très cool! Aucune obligation d'achat. Ouvert à tous les résidents des pays autorisés.

当てよう!

www.LEGOsurvey.com/product にアクセスして、アンケートにご記入ください。当選者にはレゴ®製品を差し上げます。お買い上げの必要はありません。禁止されていない限り、すべての皆様にご利用いただけます。